

Community Services Department

Planning and Building

**SPECIAL USE PERMIT**

(see page 7)

**SPECIAL USE PERMIT FOR GRADING**

(see page 9)

**SPECIAL USE PERMIT FOR STABLES**

(see page 12)

**APPLICATION**



Community Services Department  
Planning and Building  
1001 E. Ninth St., Bldg. A  
Reno, NV 89512-2845

Telephone: 775.328.6100

## Special Use Permits

Washoe County Code (WCC) Chapter 110, Article 810, Special Use Permit, provides a method of reviewing proposed uses as listed in Article 302, Allowed Uses, which possess characteristics that require special appraisal in order to determine if the uses have the potential to adversely affect other land uses, transportation systems, or public facilities in the vicinity. The Planning Commission, Board of Adjustment, or Hearing Examiner may require conditions of approval necessary to eliminate or minimize, to an acceptable level, any potentially adverse effects of the use. See WCC 110.810, for further information.

### Development Application Submittal Requirements

Applications are accepted on the 15<sup>th</sup> of each month (if the 15<sup>th</sup> is a non-work day, the first working day after the 15<sup>th</sup>)

1. **Fees:** See Master Fee Schedule. **Bring payment with your application to Community Service Department (CSD). Make check payable to Washoe County.**
2. **Development Application:** A completed Washoe County Development Application form.
3. **Owner Affidavit:** The Owner Affidavit must be signed and notarized by all owners of the property subject to the application request.
4. **Proof of Property Tax Payment:** The applicant must provide a written statement from the Washoe County Treasurer's Office indicating all property taxes for the current quarter of the fiscal year on the land have been paid.
5. **Application Materials:** The completed Special Use Permit Application materials.
6. **Proposed Site Plan Specifications (Special Use Permit and Stables):**
  - a. Lot size with dimensions drawn using standard engineering scales (e.g. scale 1" = 100', 1" = 200', or 1" = 500') showing all streets and ingress/egress to the property.
  - b. Show the location and configuration of all existing and proposed buildings (with distances from the property lines and from each other), all existing buildings that will remain (with distances from the property lines and from each other), all existing buildings that will be removed, and site improvements on a base map with existing and proposed topography expressed in intervals of no more than five (5) feet.
  - c. Show the location and configuration of wells and well houses, septic systems and leach fields, overhead utilities, water and sewer lines, and all existing and proposed easements.
  - d. Show locations of parking, landscaping, signage and lighting.
  - e. The cross sections of all rights-of-way, streets, alleys or private access ways within the proposed development, proposed name and approximate grade of each, and approximate radius of all curves and diameter of each cul-de-sac.
  - f. Property boundary lines, distances and bearings.
  - g. Contours at five (5) foot intervals or two (2) foot intervals where, in the opinion of the County Engineer, topography is a major factor in the development.
  - h. Indication of prominent landmarks, rock outcroppings, and natural foliage which will be deciding considerations in the design of the development.
  - i. If any portion of the land within the boundary of the development is subject to inundation or storm water overflow, as shown on the adopted Federal Emergency Management Agency's Flood Boundary and Floodway Maps, that fact and the land so affected shall be clearly shown on the map by a prominent note on each sheet, as well as width and direction of flow of each water course within the boundaries of the development.
  - j. Existing and proposed roads, trails or rights-of-way within the development shall be designated on the map. Topography and existing developments within three hundred (300) feet must also be shown on the map.



- k. Vicinity map showing the proposed development in relation to Interstate 80, Highway 395, I-580, or a major arterial. The vicinity map shall also include a north arrow.
- l. Date, scale, and number of each sheet in relation to the total number of sheets, and the name of the person preparing the plans.
- m. Location of snow storage areas sufficient to handle snow removed from public and private street, if above 5,500 feet.
- n. All known areas of potential hazard (and the basis for delineation) shall be clearly designated on the map. Additionally, active fault lines (post-Holocene) shall be delineated on the map.
- o. Location of areas with slopes greater than fifteen percent (15%) and thirty percent (30%).
- p. Boundary of any wetland areas and/or floodplains within the project site.
- q. Note by the project engineer or design professional indicating compliance with all applicable provisions of the Washoe County Development Code.
- r. Significant Hydrological Resources. Indicate the critical and sensitive buffer zones according to Article 418 of the Washoe County Development Code.

**7. Site Plan Specifications for Grading:**

- a. Location and limits of all work to be done.
  - b. Existing contours and proposed contours.
  - c. Location of any structures on adjacent parcels that are within fifteen (15) feet of the work site's parcel boundary.
  - d. Existing draining (natural and man-made) and proposed drainage patterns.
  - e. Sufficient elevation data to show the drainage will work as proposed.
  - f. Quantities of excavation fill and disturbed surface area shall be calculated and shown on the site plan. **Areas under buildings and pavement need not be included in these calculations.**
  - g. Quantities of material proposed to be removed from the site must be shown. The proposed disposal area and the disposition of fill must be noted on the plan.
  - h. Limiting dimensions of cut and fill.
  - i. Proposed BMPs (Best Management Practices) for controlling water and wind erosion if a disturbed area is left undeveloped for more than thirty (30) days.
  - j. Cut and fill slopes setback from the property boundary.
  - k. Structure setbacks from a slope.
8. **Grading:** In accordance with the grading provisions of Washoe County Code, Article 438, if the thresholds for a grading permit are met or exceeded, the grading plans shall indicate the existing and proposed grades, slope treatments (i.e. rip rap, erosion control, etc.) and drainage channels and the direction of flow. **Cross sections must be provided at a minimum of two key locations.**
9. **Traffic Impact Report (Special Use Permit and Stables):** Traffic impact reports are required whenever the proposed development project will generate 80 or more weekday peak hour trips as determined using the latest edition Institute of Transportation Engineers (ITE) trip generation rates or other such sources as may be accepted by Washoe County Engineering. Projects with less than 200 peak hour trips may not need to perform an impact analysis for future years. Traffic consultants are encouraged to contact Washoe County Engineering and Capital Projects staff prior to preparing a traffic impact report.
10. **Landscaping:** Landscape plans may be required, for **stables**. Landscape plans may include: a soils evaluation; color and type of building material, such as fencing material; type of plant material; location of plant material and proposed maintenance schedule; size of plant material at planting and size of plant material at full maturation; type and amount of mulch material; and an irrigation plan.
- a. **Planting Plan Specifications:** The planting plan must include all necessary information to satisfy Washoe County Code Section 110.412.60, Planting Standards.

- Proposed Tree Locations. Individual trees shall be graphically depicted in the proposed locations; trees shall be identified as either evergreen or deciduous; trees shall be individually labeled or coded and cross referenced to the proposed plant species in the plant legend.
  - Proposed Plant Material. The preliminary plan must identify where, and a square footage amount for, one or all of the following items: trees, mulch (rock, DG or bark), seeded areas, etc.
  - Existing On-Site Vegetation. In the case of large strands of trees and shrubs, individual locations may be identified with a revision cloud symbol. Smaller numbers or strands of trees (six (6) inch caliper and greater) shall be identified individually. Shrub areas and other forms of vegetation such as grasses shall be identified with a revision cloud symbol.
  - Plant Legend. Legend shall include all proposed plant material, including the following: common name, botanical name, size at planting, spacing and quantity (of trees only).
  - Landscape Area Legend. A summary of proposed areas and their square footages shall include: lawn, existing and or proposed paving, existing trees to be preserved, existing trees to be removed and the amount of proposed shrubs.
- b. **Irrigation Plan Specifications:** The irrigation plan must include all necessary information to satisfy Washoe County Code Section 110.412.65, Irrigation Standards.
- Location, size, and specifications of water source(s), water mains, meter(s), valves, and the controller.
  - Temporary or permanent water irrigation systems.
  - Specifications of irrigation equipment identified by manufacturer's name and equipment identification number.
  - An approved backflow prevention device is required on all landscape irrigation systems.
11. **Signage Plan:** The signage plans shall include sign elevations and delineate location, height, style, dimensions, intensity of sign lighting and finish of any proposed signage:
12. **Lighting Plan:** Show the location and configuration of all proposed exterior lighting including a detail of the parking lot light fixtures, pole heights, security lighting, and wall mounted illumination fixtures. Parking lot areas shall be depicted showing lumen isolines demonstrating compliance with the provisions of the Washoe County Development Code.
13. **Building Elevations:** All buildings and structures including fences, walls, poles and monument signs proposed for construction within the project shall be clearly depicted in vertical architectural drawings provided in accurate architectural scale. All architectural elevations from all building faces shall be presented.
14. **Packets:** Six (6) packets and a flash drive or DVD - any digital documents need to have a resolution of 300 dpi. One (1) packet must be labeled "Original" and contain a signed and notarized Owner Affidavit. Each packet shall include an 8.5" x 11" reduction of any applicable site plan, development plan, and/or application map. These materials must be readable. Labeling on these reproductions should be no smaller than 8 point on the 8½ x 11" display. Four (4) of the application packets shall include large format maps; the rest of the packets shall include either 8.5" x 11" or 11" x 17" maps. Large format sheets should be included in a slide pocket(s). Any specialized reports identified above shall be included as attachments or appendices and be annotated as such.

- Notes:
- (i) Application and map submittals must comply with all specific criteria as established in the Washoe County Development Code and/or the Nevada Revised Statutes.
  - (ii) Appropriate map engineering and building architectural scales are subject to the approval of Planning and Building and/or Engineering and Capital Projects.
  - (iii) All oversized maps and plans must be folded to a 9" x 12" size.
  - (iv) **Labels:** The applicant is required to submit three (3) sets of mailing labels for every tenant residing in a mobile home park that is within five hundred (500) feet of the

proposed project (or within seven hundred fifty (750) feet of the proposed project if the proposed project is a project of regional significance).

- (v) Based on the specific nature of the development request, Washoe County reserves the right to specify additional submittal packets, additional information and/or specialized studies to clarify the potential impacts and potential conditions of development to minimize or mitigate impacts resulting from the project. **No application shall be processed until the information necessary to review and evaluate the proposed project is deemed complete by the Director of Planning and Building.**
- (vi) Please be advised that the Washoe County Director of Planning and Building or their designee, Washoe County Board of Adjustment, and/or Washoe County Planning Commission have the ability to determine an application incomplete if they cannot ascertain what the applicant is requesting, or if there is insufficient information to determine a favorable outcome.

## Washoe County Development Application

Your entire application is a public record. If you have a concern about releasing personal information, please contact Planning and Building staff at 775.328.6100.

<b>Project Information</b>		Staff Assigned Case No.: _____	
Project Name:			
Project Description:			
Project Address:			
Project Area (acres or square feet):			
<b>Project Location (with point of reference to major cross streets AND area locator):</b> <small>The project site is located on Thomas Creek approximately 500 ft. upstream of the Zolezzi Lane bridge, which in turn is located about 250 ft. west of the north terminus of Welcome Way. For many years there has been a use trail along the south side of Thomas Creek upstream from Zolezzi Lane. However, the use trail crossed some private parcels which have recently been fenced off and Washoe County Parks and Open Space wishes to reroute the trail so that it lies within APN 152-021-07 which is owned by Washoe County. This will require that the trail start at Zolezzi Lane on the north side of Thomas Creek and cross the creek on APN 152-021-07.</small>			
Assessor's Parcel No.(s):	Parcel Acreage:	Assessor's Parcel No.(s):	Parcel Acreage:
<b>Indicate any previous Washoe County approvals associated with this application:</b> Case No.(s).			
<b>Applicant Information (attach additional sheets if necessary)</b>			
<b>Property Owner:</b>		<b>Professional Consultant:</b>	
Name:		Name:	
Address:		Address:	
Zip:		Zip:	
Phone:		Phone:	
Fax:		Fax:	
Email:		Email:	
Cell:		Cell:	
Other:		Other:	
Contact Person:		Contact Person:	
<b>Applicant/Developer:</b>		<b>Other Persons to be Contacted:</b>	
Name:		Name:	
Address:		Address:	
Zip:		Zip:	
Phone:		Phone:	
Fax:		Fax:	
Email:		Email:	
Cell:		Cell:	
Other:		Other:	
Contact Person:		Contact Person:	
<b>For Office Use Only</b>			
Date Received:		Initial:	
County Commission District:		Planning Area:	
CAB(s):		Master Plan Designation(s):	
		Regulatory Zoning(s):	



# Special Use Permit Application Supplemental Information

(All required information may be separately attached)

1. What is the project being requested?

2. Provide a site plan with all existing and proposed structures (e.g. new structures, roadway improvements, utilities, sanitation, water supply, drainage, parking, signs, etc.)

3. What is the intended phasing schedule for the construction and completion of the project?

4. What physical characteristics of your location and/or premises are especially suited to deal with the impacts and the intensity of your proposed use?

5. What are the anticipated beneficial aspects or affects your project will have on adjacent properties and the community?

6. What are the anticipated negative impacts or affect your project will have on adjacent properties? How will you mitigate these impacts?

7. Provide specific information on landscaping, parking, type of signs and lighting, and all other code requirements pertinent to the type of use being purposed. Show and indicate these requirements on submitted drawings with the application.

No landscaping, parking, signs or lighting is proposed for this project. See Attachment A for special review considerations under Article 418 Significant Hydrological Resources.

8. Are there any restrictive covenants, recorded conditions, or deed restrictions (CC&Rs) that apply to the area subject to the special use permit request? (If so, please attach a copy.)

<input type="checkbox"/> Yes	<input type="checkbox"/> No
------------------------------	-----------------------------

9. Utilities:

a. Sewer Service	
b. Electrical Service	
c. Telephone Service	
d. LPG or Natural Gas Service	
e. Solid Waste Disposal Service	
f. Cable Television Service	
g. Water Service	

For most uses, Washoe County Code, Chapter 110, Article 422, Water and Sewer Resource Requirements, requires the dedication of water rights to Washoe County. Please indicate the type and quantity of water rights you have available should dedication be required.

h. Permit #		acre-feet per year	
i. Certificate #		acre-feet per year	
j. Surface Claim #		acre-feet per year	
k. Other #		acre-feet per year	

Title of those rights (as filed with the State Engineer in the Division of Water Resources of the Department of Conservation and Natural Resources).

--

10. Community Services (provided and nearest facility):

a. Fire Station	
b. Health Care Facility	
c. Elementary School	
d. Middle School	
e. High School	
f. Parks	
g. Library	
h. Citifare Bus Stop	

**Special Use Permit Application  
for Grading  
Supplemental Information**  
(All required information may be separately attached)

1. What is the purpose of the grading?

2. How many cubic yards of material are you proposing to excavate on site?

45 CY

3. How many square feet of surface of the property are you disturbing?

2,130 SF of disturbance would occur within the limits of the proposed trail alignment and bridge crossing.

4. How many cubic yards of material are you exporting or importing? If none, how are you managing to balance the work on-site?

5. Is it possible to develop your property without surpassing the grading thresholds requiring a Special Use Permit? (Explain fully your answer.)

6. Has any portion of the grading shown on the plan been done previously? (If yes, explain the circumstances, the year the work was done, and who completed the work.)

7. Have you shown all areas on your site plan that are proposed to be disturbed by grading? (If no, explain your answer.)



8. Can the disturbed area be seen from off-site? If yes, from which directions and which properties or roadways?

9. Could neighboring properties also be served by the proposed access/grading requested (i.e. if you are creating a driveway, would it be used for access to additional neighboring properties)?

10. What is the slope (horizontal/vertical) of the cut and fill areas proposed to be? What methods will be used to prevent erosion until the revegetation is established?

11. Are you planning any berms?

Yes	No	If yes, how tall is the berm at its highest?
-----	----	--

12. If your property slopes and you are leveling a pad for a building, are retaining walls going to be required? If so, how high will the walls be and what is their construction (i.e. rockery, concrete, timber, manufactured block)?

13. What are you proposing for visual mitigation of the work?

14. Will the grading proposed require removal of any trees? If so, what species, how many and of what size?

15. What type of revegetation seed mix are you planning to use and how many pounds per acre do you intend to broadcast? Will you use mulch and, if so, what type?

Washoe County parks will use an upland seed blend provided by Comstock seed that includes native shrubs, grasses, and forbs within any disturbed areas outside of the trail tread at a seeding rate of 18 PLS lbs. per acre. No mulch will be used. Disturbance outside of the trail tread is expected to be minimal. Baltic rush and Nebraska sedge may be seeded in disturbance areas immediately adjacent to the bridge within the floodplain. Willow cuttings taken from shrubs on site may also be used within the riparian area.

16. How are you providing temporary irrigation to the disturbed area?

--

17. Have you reviewed the revegetation plan with the Washoe Storey Conservation District? If yes, have you incorporated their suggestions?

--

18. Are there any restrictive covenants, recorded conditions, or deed restrictions (CC&Rs) that may prohibit the requested grading?

Yes	No	If yes, please attach a copy.
-----	----	-------------------------------

## ATTACHMENT A:

### Special Review Considerations for Article 418 Significant Hydrological Resources

#### **(a) Conservation of topsoil;**

Approximately 2,130 square feet of disturbance is proposed as part of this recreational trail project. Sustainable trail building standards that minimize erosion and movement of topsoil after trail construction would be followed. Topsoil would be removed within the 5-foot wide trail corridor and broadcast on the downhill side of the trail. Vegetation on the downslope side of the trail would not be affected. No material would be removed from the site.

Trail finishing work would be conducted by hand crews. Trail finishing work consists of the following: The 3-foot wide trail tread would be compacted and the back slope would be seeded and compacted to conserve remaining soil. Soil broadcast on the downhill side of the trail would be smoothed and nearby surface duff and debris would be spread on top of the area to give it a natural undisturbed appearance.

Fiber rolls would be placed around the bridge abutments and within 20-feet of creek banks to prevent any potential soil movement into Thomas Creek. Fiber rolls would be placed prior to start of work and left in place until revegetation of disturbed areas is complete.

#### **(b) Protection of surface water quality;**

No chemicals or other substances that could affect water quality are proposed for use as part of this project. Potential sedimentation from trail construction would be addressed by following best management practices for water quality protection. Fiber rolls would be placed around the bridge abutments and trail within 20-feet of creek banks to prevent sediment from entering Thomas Creek. Fiber rolls would be placed prior to start of work and left in place until revegetation of disturbed areas is complete. A Stormwater Pollution Prevention Plan (SWPPP) would also be required from the contractor prior to trail and bridge construction.

#### **(c) Conservation of natural vegetation, wildlife habitats and fisheries;**

This trail project was designed to preserve the character of the site and have a minimal impact on site vegetation and habitat. The low flow bridge installation would result in partial removal of two existing 10-foot tall willow shrubs. These willow shrubs are expected to recover and grow back in over time. Any additional disturbance areas outside of the 3-foot wide trail tread would be revegetated. Best management practices to control erosion and protect water quality would be followed. Impacts to wildlife habitat and fisheries would be minimal if any.

#### **(d) Control of erosion;**

Trail design will follow sustainable trail building standards that minimize erosion including utilizing a full bench cut with a 5% out slope on the trail tread, compaction of trail tread and back slope (cut slope), use of rolling grade dips, and a running slope of 10% or less. Best management practices would be

followed to control erosion including placing fiber rolls around the bridge abutments and within 20-feet of creek banks and revegetation of disturbed areas.

**(e) Control of drainage and sedimentation;**

No additional drainage areas would be created by this project. Sustainable trail design standards and best management practices would be utilized as described above to minimize erosion and sedimentation into Thomas Creek.

**(f) Provision for restoration of the project site to predevelopment conditions;**

All disturbed areas outside of the 3-foot wide trail tread would be revegetated. Washoe County parks will use an upland seed blend provided by Comstock Seed that includes native shrubs, grasses, and forbs at a rate of 18 PLS lbs. per acre. Seed would be broadcast and raked into the soil at a depth of approximately ¼-inch. Revegetation within the riparian corridor may include seeding with Baltic rush and Nebraska sedge, and planting of willow stakes harvested on site.

Utilities are not present on site and irrigation is not practical on this open space parcel. Seeding would be done in the fall to maximize the success rate. Site monitoring would occur in summer 2021 to determine success of revegetation efforts. A minimum 50% cover of shrubs, grasses, and forbs within disturbed areas would be considered successful. Additional planting and seeding may occur in fall 2021 with follow-up monitoring if needed.

**(g) Provision of a bonding program to secure performance of requirements imposed; and**

Washoe County Parks is the project applicant and would be responsible for performance of requirements imposed. Washoe County Parks would implement the revegetation plan and conduct monitoring and additional planting/seeding as needed until revegetation is successful.

**(h) Preservation of the hydrologic resources, character of the area and other conditions as necessary.**

For many years there was an existing trail along the south side of Thomas Creek upstream from Zolezzi Lane. The trail crossed a private parcel on which no easement had been secured. The private property owner removed and fenced off this trail section in 2018. In response to numerous complaints and requests from the public, Washoe County Parks would like to reroute this portion of trail so that it lies within APN 152-021-07 which is owned by the County. This requires the trail to start at Zolezzi Lane on the north side of Thomas Creek and cross the creek via bridge on APN 152-021-07 to connect to the existing trail. The existing Lower Thomas Creek trail continues up through Arrowcreek Park and eventually ties into the Thomas Creek Trailhead.

This trail project was designed to preserve the character of the site and have a minimal impact on site vegetation, habitat, and hydrologic resources. No landscaping, lighting, signage, or parking is proposed.

Thomas Creek has a regulatory floodplain that is approximately 150 feet wide at this point. Spanning the entire floodplain would require a major structure that is cost prohibitive for a recreational trail. Washoe

County Parks would like to construct a low flow bridge that will span the low flow channel, recognizing that it will be overtopped in large flood events. The bridge design calls for a 5-foot wide, 16-foot long wooden bridge that would be anchored to withstand the 10-year flow. It is acknowledged that in a major storm event it is possible that the bridge would be washed away. No impacts to adjacent or downstream properties are expected. See attached Thomas Creek Low Flow Bridge Drainage Memo for additional details.

**ATTACHMENT B: Site Photos**



**Figure 1: Proposed bridge crossing on Thomas Creek.**



**Figure 2: Trail reroute section looking toward Zolezzi Lane from near the bridge crossing.**



Account Detail

[Back to Account Detail](#)
[Change of Address](#)
[Print this Page](#)

CollectionCart		
Collection Cart	Items	Total
	0	\$0.00

[Checkout](#)
[View](#)

**Pay Online**

No payment due for this account.

Washoe County Parcel Information		
Parcel ID	Status	Last Update
15202107	Active	3/13/2020 2:08:53 AM

**Current Owner:**  
 WASHOE COUNTY  
 ATTN COMMUNITY SERVICES DEPT  
 1001 E 9TH ST BLDG A  
 RENO, NV 89512

**SITUS:**  
 0 GRANITE POINTE CT  
 WCTY NV

**Taxing District:**  
 4000

**Geo CD:**

Legal Description

Township 18 SubdivisionName \_UNSPECIFIED Range 19 Lot 2

Tax Bill (Click on desired tax year for due dates and further details)					
Tax Year	Net Tax	Total Paid	Penalty/Fees	Interest	Balance Due
<a href="#">2019</a>	\$0.00	\$0.00	\$0.00	\$0.00	\$0.00
<a href="#">2018</a>	\$0.00	\$0.00	\$0.00	\$0.00	\$0.00
<a href="#">2017</a>	\$0.00	\$0.00	\$0.00	\$0.00	\$0.00
<a href="#">2016</a>	\$0.00	\$0.00	\$0.00	\$0.00	\$0.00
<a href="#">2015</a>	\$0.05	\$0.05	\$0.00	\$0.00	\$0.00
<b>Total</b>					<b>\$0.00</b>

**Disclaimer**

- ALERTS:** If your real property taxes are delinquent, the search results displayed may not reflect the correct amount owing. Please contact our office for the current amount due.
- For your convenience, online payment is available on this site. E-check payments are accepted without a fee. However, a service fee does apply for online credit card payments. See Payment Information for details.

**Pay By Check**

Please make checks payable to:  
WASHOE COUNTY TREASURER

**Mailing Address:**  
P.O. Box 30039  
Reno, NV 89520-3039

**Overnight Address:**  
1001 E. Ninth St., Ste D140  
Reno, NV 89512-2845

 **Payment Information**

 **Special Assessment District**

 **Installment Date Information**

 **Assessment Information**

# THOMAS CREEK LOW FLOW BRIDGE DRAINAGE MEMO

JN: 9913.000

Date: October 25, 2019

By: Chas Macquarie, P.E.

## Project Background

The project site is located on Thomas Creek approximately 500 ft. upstream of the Zolezzi Lane bridge, which in turn is located about 250 ft. west of the north terminus of Welcome Way. For many years there has been a use trail along the south side of Thomas Creek upstream from Zolezzi Lane. However, the use trail crossed some private parcels which have recently been fenced off and Washoe County Parks and Open Space wishes to reroute the trail so that it lies within APN 152-021-07 which is owned by Washoe County. This will require that the trail start at Zolezzi Lane on the north side of Thomas Creek and cross the creek on APN 152-021-07.

Thomas Creek has a regulatory floodplain that is approximately 150 feet wide at this point and spanning the entire floodplain would require a major structure that is cost prohibitive for a use trail. Thus Parks and Open Space wishes to construct a low flow bridge that will span the low flow channel, recognizing that it will be overtopped in large flood events.

The bridge will be located about 50 feet upstream (west) of the west property line of APN 049-165-06 and will span the normal flow creek channel with a span of 16 feet. It is recognized that the bridge will not pass significant storm events and that in a major storm event it is possible that the bridge will be washed away even though the bridge will be anchored to withstand the 10-year flow.

The bridge will have a width of 5 feet and consist of two 16 ft. long 6" x 12" treated timber beams with 2" x 4" treated stringers and 2" x 12" treated decking planks (See the project plans). The stringers will be attached to the bottom of the beams to maximize the flow area under the structure while limiting the height of the deck to just less than 30" above the stream bed. Thus railings will not be required. The structure will be anchored to four 3-1/2" galvanized steel pipes that have been sized to withstand the force of the 10-year flow.

## Hydrology

There is no USGS stream flow data available for Thomas Creek on the USGS website.

The US Army Corps of Engineers report titled *Section 205 Reconnaissance Investigation Thomas Creek, Nevada*, dated May 1993, determined the 10-year flow at this location to be 685 cfs and the 100-year flow to be 2,640 cfs.

The report titled *Statistical Generation and Analysis of Streamflow Data for Galena, Whites, Thomas and Hunter Creeks, Truckee Meadows, Washoe County, Nevada*, dated June 21, 2000 by Michael Widmer predicts exceedance probabilities for these creeks. Table 15, page 11 (attached) gives the 60%



exceedance for a 3-day high flow event on Thomas Creek at less than 10 cfs. This is the best estimate we have found for an "average" flow on Thomas Creek.

## Hydraulic Analysis

The stream cross section at the proposed bridge site was measured in the field and the Haestad Methods Flowmaster program was used to estimate the amount of flow that will pass under the bridge. The program predicts that approximately 160 cfs will pass under the bridge in a subcritical flow regime.

The 10-year water surface elevation at the bridge site was determined using the Haestad Methods Flowmaster program for normal and critical depths. The program predicts a subcritical flow regime with a normal depth of 3.45 feet. Thus the 10-year flow will overtop the bridge by approximately 1 ft.

The approximate 100-year water surface elevation at the bridge site was determined using the Haestad Methods Flowmaster program for normal and critical depths using contour information available from Washoe County. The program predicts a supercritical flow regime with a normal depth of 5.5 feet and a critical depth of 6.1 feet. Thus the 100-year flow will overtop the bridge by approximately 3.6 ft. The 100-year flow area will be about 219 sq. ft. with a top width of about 79 feet. The effective area of the bridge that would reduce the flow area is 14 sq. ft. (since the ends of the bridge are screened by bank vegetation) which is a reduction in cross-sectional area of about 6.5%. If you apply this reduction over the top width it would result in an increase of about 0.2 feet in the flood elevation. This would not impact the properties in the immediate area because the existing banks on either side of the flood area rise for over 20 feet before any developed land is reached. Since it is probable that the bridge would wash away in the 100-year event, it is unlikely to impact the 100-year water surface elevation at all.

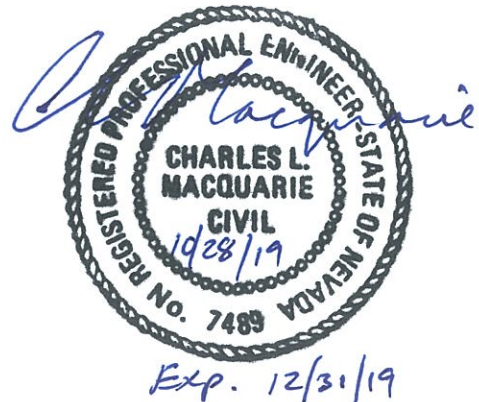



---

## Worksheet for Section - 2, under bridge

---

### Results

Top Width	13.81	ft
Normal Depth	2.00	ft
Critical Depth	1.95	ft
Critical Slope	0.03630	ft/ft
Velocity	7.01	ft/s
Velocity Head	0.76	ft
Specific Energy	2.76	ft
Froude Number	0.95	
Flow Type	Subcritical	

### GVF Input Data

Downstream Depth	0.00	ft
Length	0.00	ft
Number Of Steps	0	

### GVF Output Data

Upstream Depth	0.00	ft
Profile Description		
Profile Headloss	0.00	ft
Downstream Velocity	Infinity	ft/s
Upstream Velocity	Infinity	ft/s
Normal Depth	2.00	ft
Critical Depth	1.95	ft
Channel Slope	0.03300	ft/ft
Critical Slope	0.03630	ft/ft







## Worksheet for Section - 2, bridge, 10-year flow

### Results

Normal Depth		3.45	ft
Elevation Range	4949.30 to 4960.00 ft		
Flow Area		102.38	ft <sup>2</sup>
Wetted Perimeter		56.45	ft
Hydraulic Radius		1.81	ft
Top Width		55.13	ft
Normal Depth		3.45	ft
Critical Depth		3.26	ft
Critical Slope		0.04508	ft/ft
Velocity		6.69	ft/s
Velocity Head		0.70	ft
Specific Energy		4.15	ft
Froude Number		0.87	
Flow Type	Subcritical		

### GVF Input Data

Downstream Depth		0.00	ft
Length		0.00	ft
Number Of Steps		0	

### GVF Output Data

Upstream Depth		0.00	ft
Profile Description			
Profile Headloss		0.00	ft
Downstream Velocity		Infinity	ft/s
Upstream Velocity		Infinity	ft/s
Normal Depth		3.45	ft
Critical Depth		3.26	ft
Channel Slope		0.03300	ft/ft
Critical Slope		0.04508	ft/ft







## Worksheet for Section - 1, 100-year flow at bridge

### Options

Current roughness weighted Method	Pavlovskii's Method
Open Channel Weighting Method	Pavlovskii's Method
Closed Channel Weighting Method	Pavlovskii's Method

### Results

Normal Depth		5.52	ft
Elevation Range	4949.30 to 4970.00		ft
Flow Area		219.04	ft <sup>2</sup>
Wetted Perimeter		78.81	ft
Hydraulic Radius		2.78	ft
Top Width		77.30	ft
Normal Depth		5.52	ft
Critical Depth		6.12	ft
Critical Slope		0.02028	ft/ft
Velocity		12.05	ft/s
Velocity Head		2.26	ft
Specific Energy		7.78	ft
Froude Number		1.26	
Flow Type	Supercritical		

### GVF Input Data

Downstream Depth	0.00	ft
Length	0.00	ft
Number Of Steps	0	

### GVF Output Data

Upstream Depth	0.00	ft
Profile Description		
Profile Headloss	0.00	ft
Downstream Velocity	Infinity	ft/s
Upstream Velocity	Infinity	ft/s
Normal Depth	5.52	ft
Critical Depth	6.12	ft
Channel Slope	0.03300	ft/ft
Critical Slope	0.02028	ft/ft

## Cross Section for Section - 1, 100-year flow at bridge

### Project Description

Friction Method                      Manning Formula  
Solve For                                Normal Depth

### Input Data

Channel Slope    0.03300    ft/ft  
Normal Depth    5.52        ft  
Discharge    2640.00   ft<sup>3</sup>/s

### Cross Section Image

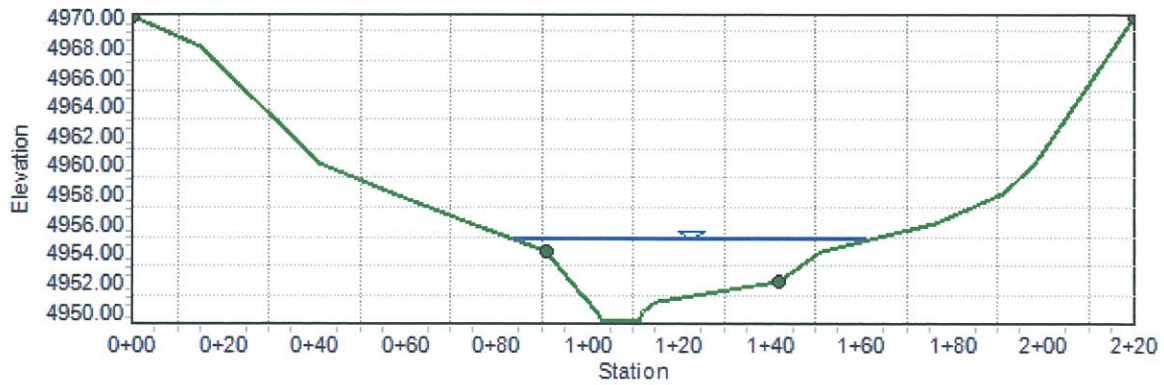



STATISTICAL GENERATION AND ANALYSIS  
OF STREAMFLOW DATA FOR  
GALENA, WHITES, THOMAS AND HUNTER CREEKS  
TRUCKEE MEADOWS, WASHOE COUNTY, NEVADA

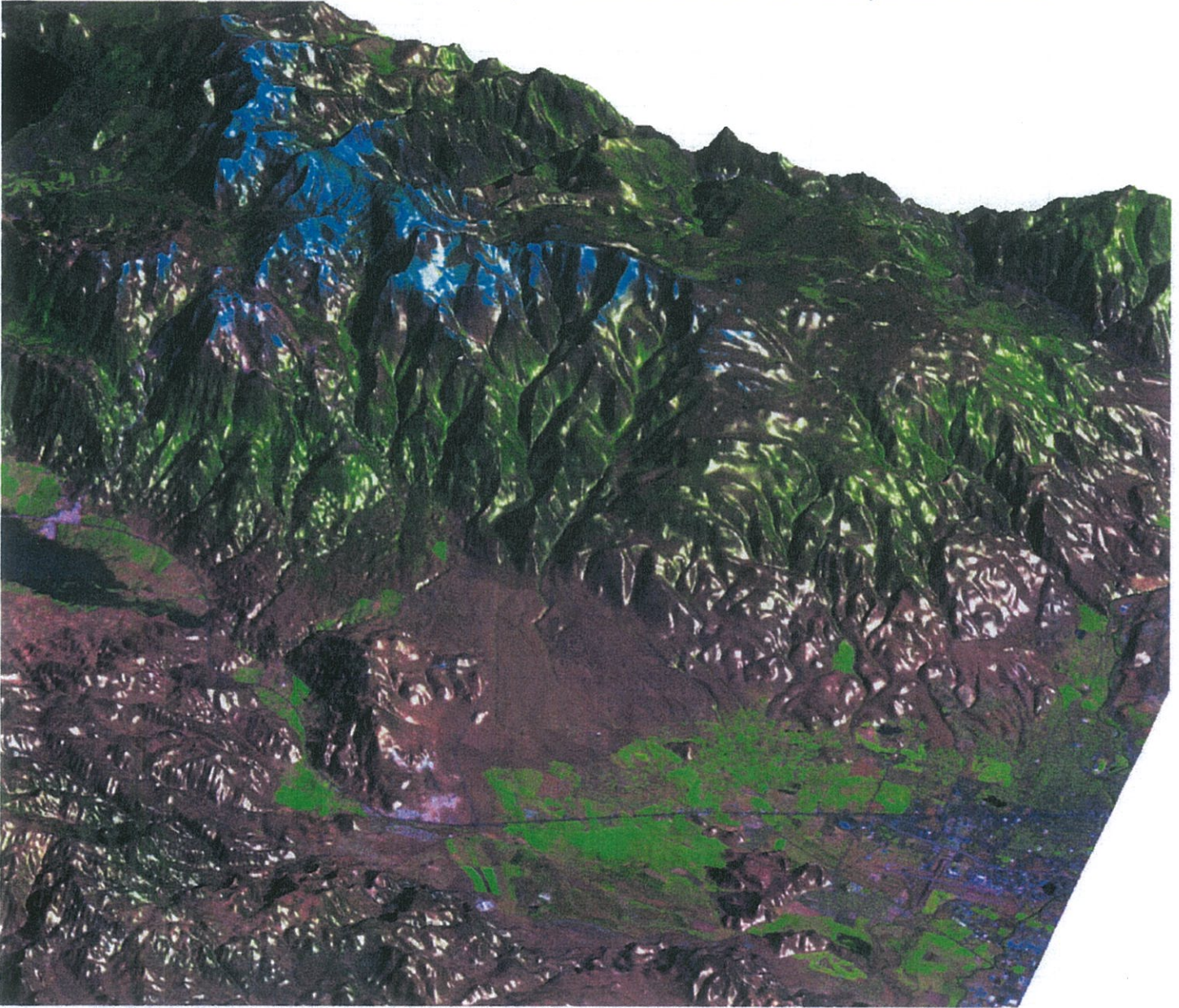

Prepared for  
Washoe County Regional Water Planning Commission  
June 21, 2000

By  
Michael C. Widmer  
Washoe County Department of Water Resources



**Table 13**  
**Results from high-flow frequency duration analysis, Whites Creek (cfs)**

high flow duration	90% exceedance	80% exceedance	60% exceedance
3-day	7.5	10.3	15.4
7-day	7.1	9.9	15.0
15-day	6.8	9.4	14.2
30-day	6.3	8.9	13.4
60-day	5.8	8.0	12.0
90-day	5.3	7.2	10.7
120-day	4.9	6.6	9.5
183-day	4.3	5.7	8.0

**Table 14**  
**Results from low-flow frequency duration analysis, Thomas Creek (cfs)**

low flow duration	10% non-exceedance	20% non-exceedance	40% non-exceedance
3-day	0.6	0.9	1.3
7-day	0.6	0.9	1.4
15-day	0.7	1.0	1.5
30-day	0.7	1.0	1.6
60-day	0.8	1.2	1.8
90-day	0.9	1.3	1.9
120-day	1.0	1.4	2.2
183-day	1.4	1.9	2.7

**Table 15**  
**Results from high-flow frequency duration analysis, Thomas Creek (cfs)**

high flow duration	90% exceedance	80% exceedance	60% exceedance
3-day	5.0	6.6	9.6
7-day	4.6	6.2	9.2
15-day	4.2	5.7	8.5
30-day	3.9	5.2	7.7
60-day	3.6	4.7	6.8
90-day	3.3	4.4	6.2
120-day	3.1	4.0	5.6
183-day	2.7	3.5	4.8

**Table 16**  
**Results from low-flow frequency duration analysis, Hunter Creek (cfs)**

low flow duration	10% non-exceedance	20% non-exceedance	40% non-exceedance
3-day	1.3	2.0	3.1
7-day	1.4	2.1	3.2
15-day	1.4	2.2	3.4
30-day	1.6	2.3	3.5
60-day	1.7	2.6	3.9
90-day	1.9	2.8	4.2
120-day	2.1	3.1	4.6
183-day	2.8	3.9	5.3



**Carson City**  
308 N. Curry Street, Suite 200  
Carson City, Nevada 89703  
775.883.7077

March 16, 2020

Washoe County Planning Department  
1001 E. 9<sup>th</sup> Street, Building A, Second Floor  
Reno, NV 89512

**RE: SUP Application for the Thomas Creek Low Flow Bridge and Approach Trail**

Dear Planning Department:

This letter is to verify that the electronic stamp and signature on the civil plans that are part of this application are a true representation of my full size stamp and signature.

Sincerely,

Charles L. Macquarie, P.E.  
Senior Project Manager

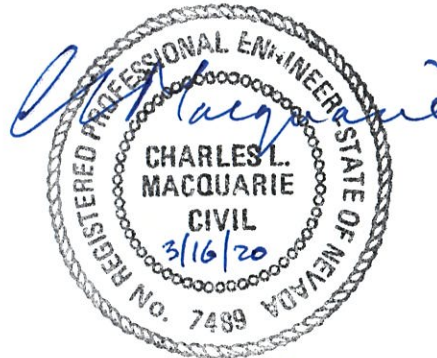

Exp. 12/31/21



# WASHOE COUNTY REGIONAL PARKS AND OPEN SPACE THOMAS CREEK LOW FLOW BRIDGE

## OCTOBER 2019



308 N. CURRY ST., STE. 200  
CARSON CITY, NV 89703  
TEL: 775.883.7077  
WWW.LUMOSINC.COM

© LUMOS & ASSOCIATES, INC. THIS DRAWING IS THE PROPERTY OF LUMOS & ASSOCIATES, INC. USE OR REPRODUCTION OF THIS DRAWING, IN WHOLE OR IN PART, WITHOUT THE WRITTEN PERMISSION OF LUMOS & ASSOCIATES, INC. IS STRICTLY PROHIBITED. THIS DRAWING IS NOT TO BE USED FOR ANY PROJECT OTHER THAN THE PROJECT FOR WHICH IT WAS PREPARED.

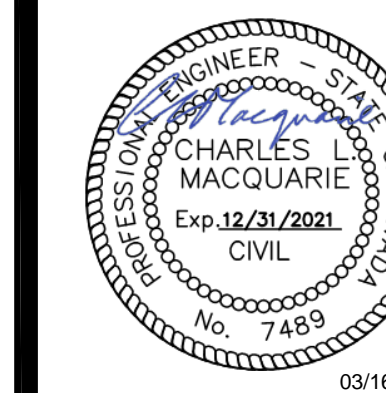

03/16/2020

WASHOE COUNTY REGIONAL PARKS AND OPEN SPACE  
THOMAS CREEK LOW FLOW BRIDGE  
TITLE SHEET  
WASHOE COUNTY  
NEVADA

REV	DATE	DESCRIPTION
1	3/7/20	Updated for SUP

**PERMIT SET**  
October 25, 2019

BAR IS 1 INCH ON ORIGINAL DRAWING  
SCALE  
IF NOT ONE INCH ON THIS SHEET, ADJUST SCALES ACCORDINGLY  
**C1.0**  
DRAWN BY: LAM  
DESIGNED BY: CLM  
CHECKED BY: CLM  
JOB NO.: 9913.000

### PREPARED FOR:



**WASHOE COUNTY REGIONAL PARKS AND OPEN SPACE**  
1001 E. 9TH STREET  
RENO, NEVADA 89520  
PH.: (775) 823-6500

### ENGINEER:



308 N. CURRY ST., STE. 200  
CARSON CITY, NEVADA 89703  
PH.: (775) 883-7077  
FAX: (775) 881-7114

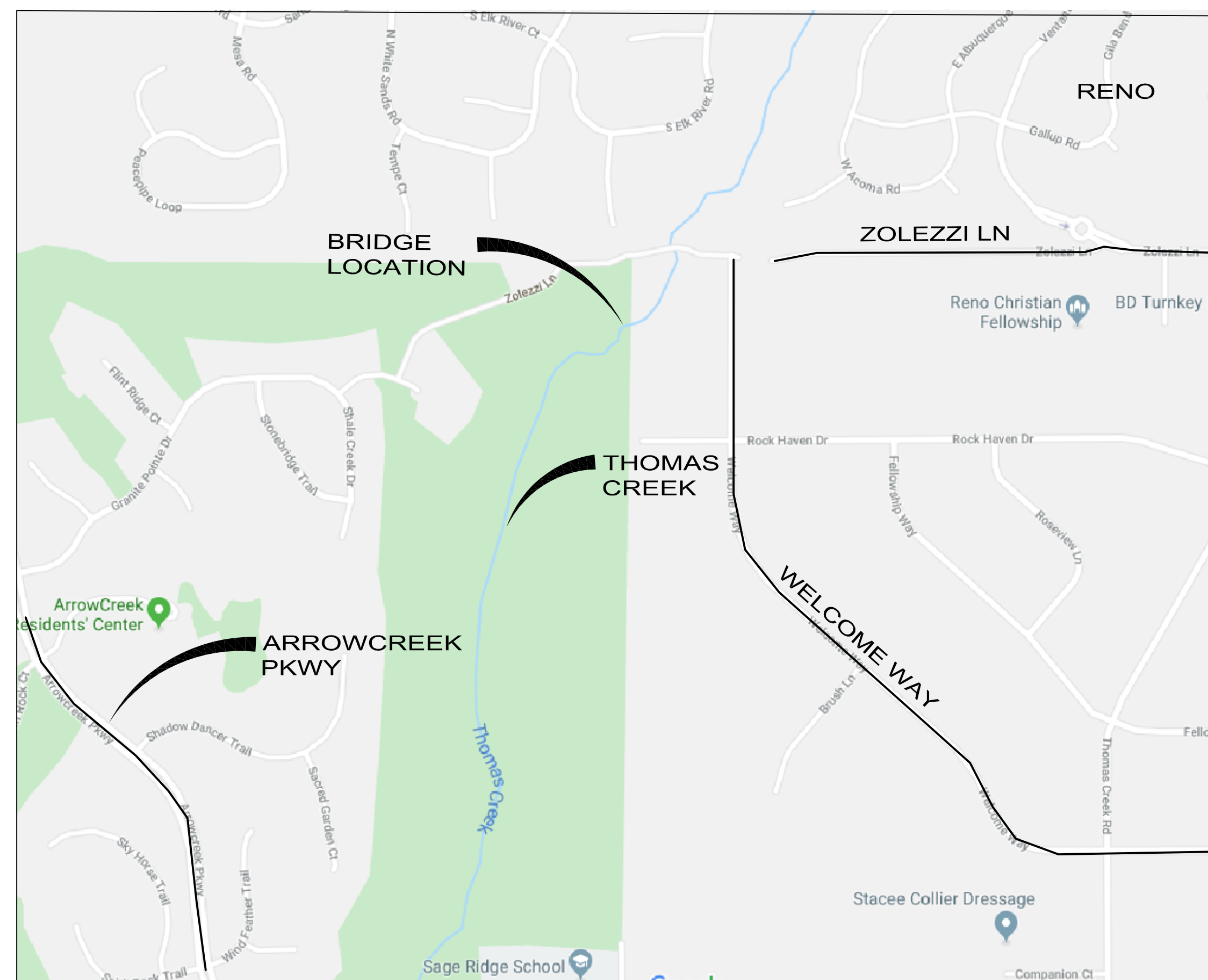

**VICINITY MAP**  
N.T.S.

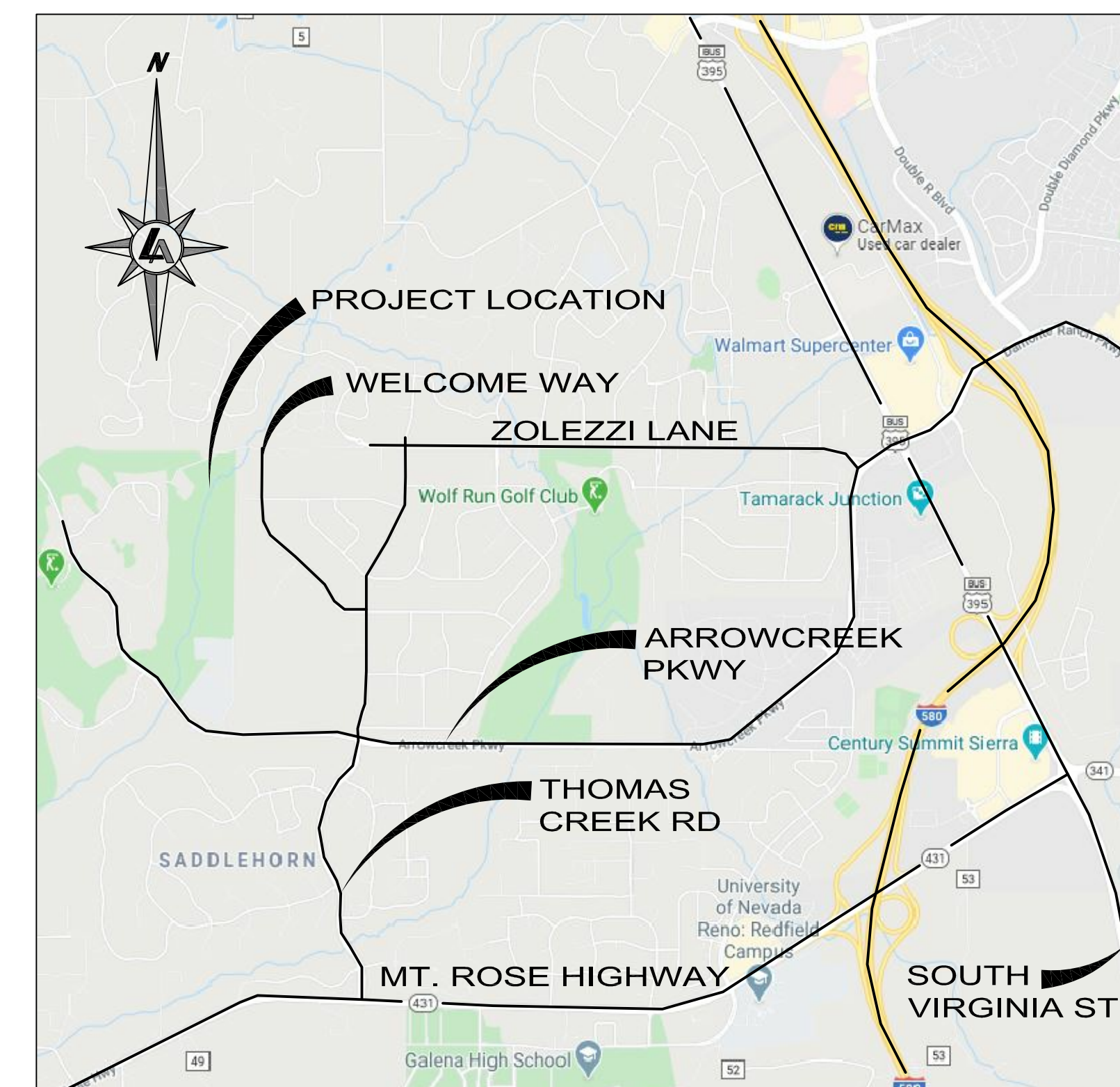

**LOCATION MAP**  
N.T.S.

### GENERAL NOTES:

- ALL CONSTRUCTION MATERIALS AND METHODS SHALL COMPLY WITH THE CURRENT "ORANGE BOOK" STANDARD SPECIFICATIONS FOR PUBLIC WORKS CONSTRUCTION AS ADOPTED BY WASHOE COUNTY.
- CONTRACTOR SHALL NOTIFY, 48 HOURS PRIOR TO ANY EXCAVATION WORK, THE FOLLOWING UNDERGROUND UTILITY SERVICE: UNDERGROUND SERVICES ASSOCIATION (USA) 1-800-227-2600.
- THE CONTRACTOR SHALL BE RESPONSIBLE FOR THE PROTECTION OF ALL EXISTING SURVEY MONUMENTS AND OTHER SURVEY MARKERS DURING CONSTRUCTION.
- THE CONTRACTOR AGREES TO ASSUME SOLE RESPONSIBILITY FOR JOB SITE CONDITIONS DURING THE COURSE OF CONSTRUCTION OF THIS PROJECT, INCLUDING SAFETY OF ALL PERSONS AND PROPERTY, AND FURTHER AGREES THAT THIS REQUIREMENT SHALL APPLY CONTINUOUSLY AND NOT BE LIMITED TO NORMAL WORKING HOURS IN ACCORDANCE WITH THE PROVISIONS OUTLINED BY THE PROJECT CONTROL AND THE STANDARD SPECIFICATIONS.
- SHOULD IT APPEAR THAT THE WORK TO BE DONE, OR ANY MATTER RELATIVE THERETO, IS NOT SUFFICIENTLY DETAILED OR EXPLAINED ON THESE PLANS, THE CONTRACTOR SHALL CONTACT THE ENGINEER FOR SUCH FURTHER EXPLANATIONS AS MAY BE NECESSARY.
- AT ALL TIMES DURING CONSTRUCTION ADEQUATE TEMPORARY EROSION CONTROLS SHALL BE IN PLACE AS SHOWN ON THE PLANS.

AC	ASPHALT CONCRETE
AGG	AGGREGATE
BVCS	BEGINNING OF VERTICAL CURVE STATION
BVCE	BEGINNING OF VERTICAL CURVE ELEVATION
C-C	CENTER TO CENTER
CMP	CORRUGATED METAL PIPE
CL	CENTER LINE
COMP	COMPACTION
CONC	CONCRETE
CP	CONTROL POINT
DF	DOUGLAS FIR
DIA	DIAMETER
ELEV	ELEVATION
EVCS	END OF VERTICAL CURVE STATION
EVCE	END OF VERTICAL CURVE ELEVATION
E	ELECTRIC
ELEC	ELECTRIC
EX	EXISTING
F	FIR TREE
FFC	FRONT FACE OF CURB
FES	FLARED END SECTION
FG	FINISH GRADE

### ABBREVIATIONS

FL	FLOW LINE
G	GAS
GALV	GALVANIZED
GB	GRADE BREAK
HDPE	HIGH DENSITY POLYETHYLENE PIPE
HP	HIGH POINT
HSS	HOLLOW SQUARE SECTION
LP	LOW POINT
LT	LEFT
LVC	LENGTH OF VERTICAL CURVE
MAX	MAXIMUM
MB	MACHINE BOLT
MH	MANHOLE
MI	?
MIN	MINIMUM
NTS	NOT TO SCALE
OC	ON CENTER
OH	OVERHEAD
P	PINE TREE
PC	POINT OF CURVE
PC	POWDER COATED

PCC	POINT OF COMPOUND CURVE
PCC	PORTLAND CEMENT CONCRETE
PL	PROPERTY LINE
PRC	POINT OF REVERSE CURVE
PRVC	POINT OF REVERSE VERTICAL CURVE
PT	POINT OF TANGENCY
PT	PRESSURE TREATED
PVC	POLYVINYL CHLORIDE
PVI	POINT OF VERTICAL INTERSECTION
PVMT	PAVEMENT
RT	RIGHT
S	SLOPE (FT./FT.)
SEZ	STREAM ENVIRONMENT ZONE
SD	STORM DRAIN
SF	SQUARE FEET
SS	SANITARY SEWER
STA	STATION
TR	TREADED
TYP	TYPICAL
W/	WITH
WL	WATERLINE

### SHEET INDEX

C1.0	TITLE SHEET
C2.0	SITE PLAN
C2.1	EXTENDED AREA SITE PLAN
S0.1	STRUCTURAL NOTES
S1.1	BRIDGE PLAN, SECTION, AND DETAILS

2 working days  
Call before you Dig.

1-800-227-2600  
AVOID CUTTING UNDERGROUND UTILITIES



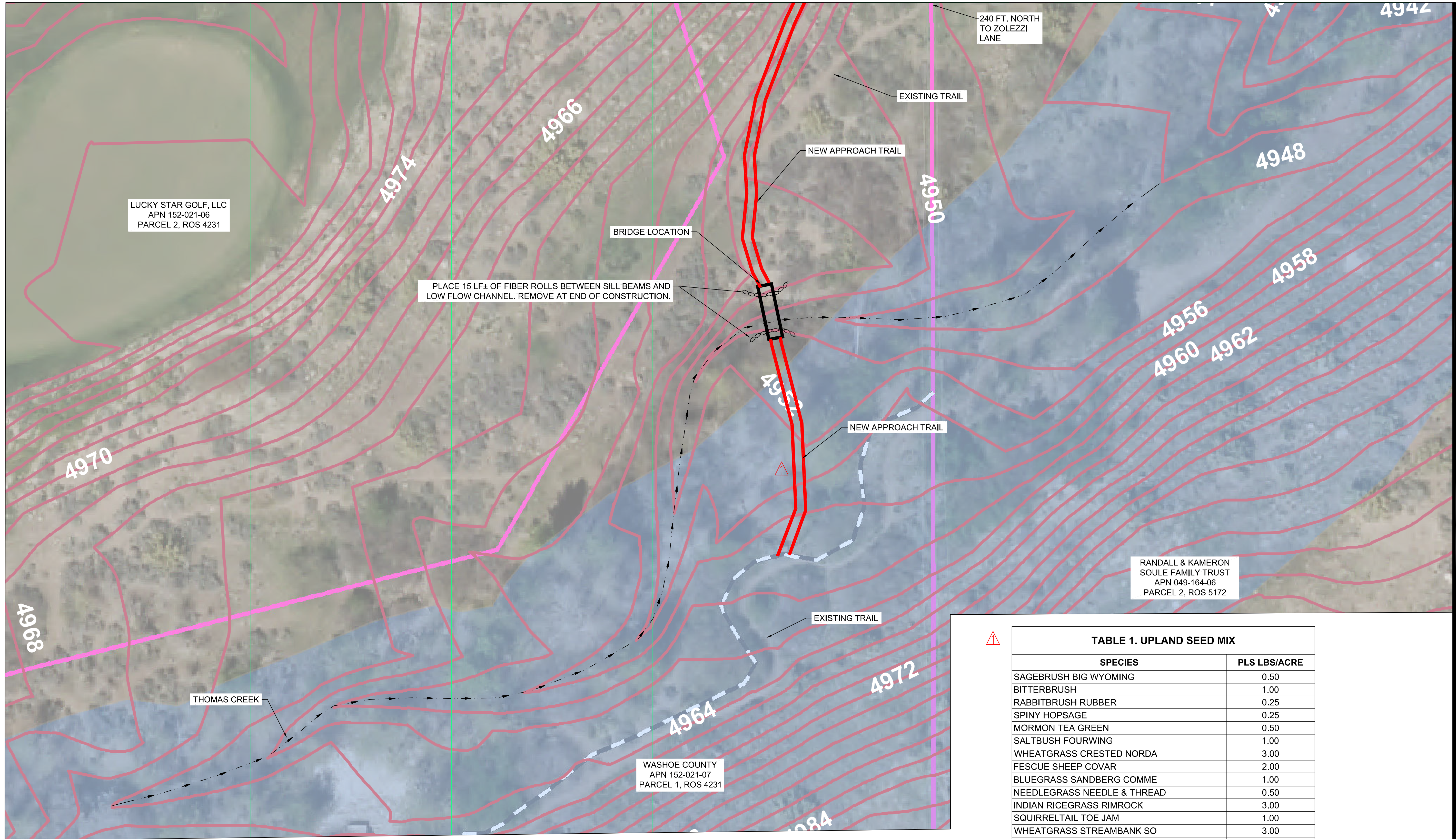

03/16/2020

**NOTES:**

1. PHOTO, APNS, AND PROPERTY LINES PROVIDED BY WASHOE COUNTY FROM COUNTY GIS DATABASE
2. NEW APPROACH TRAILS MAY BE ADJUSTED IN FIELD TO BEST FIT THE TERRAIN.
3. RESEED DISTURBED AREAS OUTSIDE THE TRAIL TREAD WITH THE SEED MIX IN TABLE 1 OR TABLE 2. RAKE SEED INTO THE CUT SLOPES.



**TABLE 1. UPLAND SEED MIX**

SPECIES	PLS LBS/ACRE
SAGEBRUSH BIG WYOMING	0.50
BITTERBRUSH	1.00
RABBITBRUSH RUBBER	0.25
SPINY HOPSAGE	0.25
MORMON TEA GREEN	0.50
SALTBUSH FOURWING	1.00
WHEATGRASS CRESTED NORDA	3.00
FESCUE SHEEP COVAR	2.00
BLUEGRASS SANDBERG COMME	1.00
NEEDLEGRASS NEEDLE & THREAD	0.50
INDIAN RICEGRASS RIMROCK	3.00
SQUIRRELTAIL TOE JAM	1.00
WHEATGRASS STREAMBANK SO	3.00
WILDRIEY BASIN	1.00
WILDFLOWER MIX DRYLAND nat.	0.25
<b>AREA TOTALS</b>	<b>18.25</b>



**TABLE 2. RIPARIAN SEED MIX**

SPECIES	PLS LBS/ACRE
BALTIC RUSH (JUNCUS BALTICUS)	0.60
NEBRASKA SEDGE (CAREX NEBRASCENSIS)	1.90
<b>AREA TOTALS</b>	<b>2.50</b>

REV	DATE	DESCRIPTION
1	10/25/2019	PERMIT SET
2	03/16/2020	Updated for SUP

**PERMIT SET**  
October 25, 2019

**C2.0**  
DRAWN BY: LAM  
DESIGNED BY: CLM  
CHECKED BY: CLM  
JOB NO.: 9913.000

L:\A\Proj\9913.000 - Thomas Creek Low Flow Bridge\DWG\9913\9913EAS022020.dwg, C2\_11X17\_22X32\_30 SCALE, 03/16/2020 10:12 am bgr@lumos.com

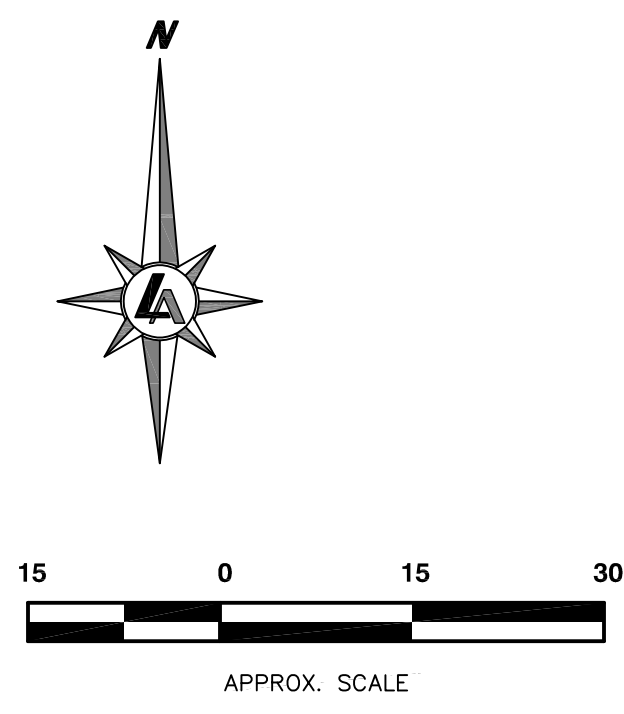



L:\AP\9913.000 - Thomas Creek Low Flow Bridge\DWG\DWG\9913.000\_1.mxd; ThomasCreek\_ExtendedArea\_SitePlan.dwg; 20 ac PLAN; 03/16/2020 09:31 am; by:cm

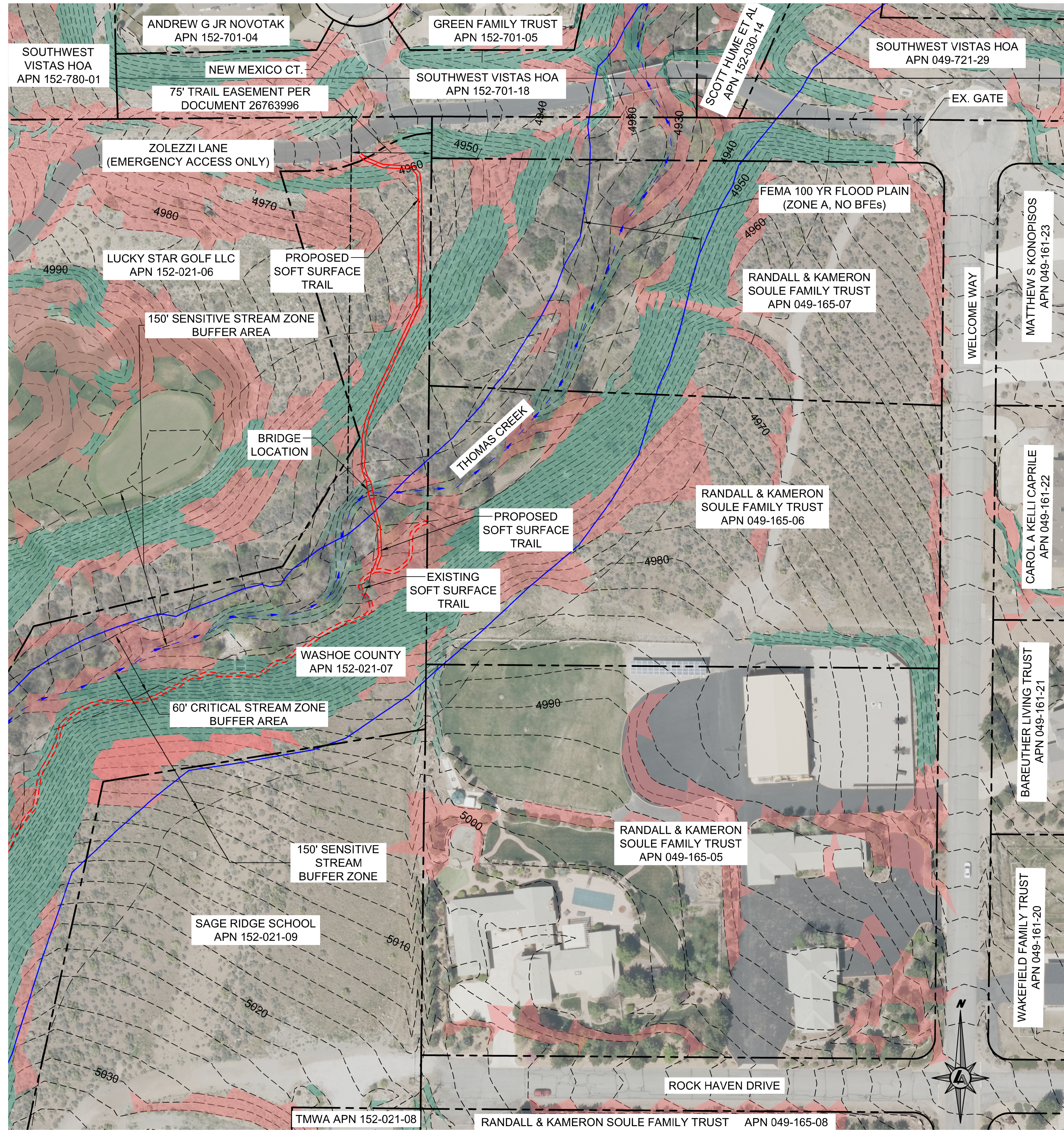

**NOTES:**

1. THE PROPOSED PROJECT IS TO CONSTRUCT A SOFT SURFACE TRAIL AND LOW FLOW BRIDGE ACROSS THOMAS CREEK.
2. THE ENTIRE PROJECT IS LOCATED WITHIN APN 152-021-07, OWNED BY WASHOE COUNTY, AND AN ASSOCIATED 75-FT. WIDE TRAIL EASEMENT, DOC. NO. 26763996.
3. THE 16-FT LONG BRIDGE AND 50-FT. OF TRAIL WILL BE LOCATED WITHIN THE 60-FT. CRITICAL STREAM ZONE BUFFER AREA OF THOMAS CREEK.
4. AN ADDITIONAL 180-FT. OF TRAIL WILL BE LOCATED WITHIN THE 150-FT. SENSITIVE STREAM ZONE BUFFER AREA OF THOMAS CREEK.
5. THERE ARE NO EXISTING OR PROPOSED BUILDINGS ON THE SITE.
6. THERE ARE NO KNOWN WELLS, SEPTIC SYSTEMS, LEACHFIELDS, OVERHEAD UTILITIES, WATER AND SEWER LINES ON THE SITE.
7. NO PARKING, LANDSCAPING, SIGNAGE OR LIGHTING IS PROPOSED ON THE SITE.
8. A PORTION OF THE PROJECT IS LOCATED WITHIN THE FEMA REGULATORY 100-YEAR FLOODPLAIN OF THOMAS CREEK. IT SHOULD BE NOTED THAT THE REGULATORY FLOODPLAIN IS NOT ACCURATE AS PORTIONS OF THOMAS CREEK ARE OUTSIDE THE REGULATORY FLOODPLAIN AND PORTIONS OF THE REGULATORY FLOODPLAIN ARE ON A BENCH 30-FT. ABOVE THE CREEK, WHICH IS WELL OUTSIDE THE ACTUAL FLOODPLAIN.
9. THERE ARE NO KNOWN HAZARD AREAS (OTHER THAN THE 100-YEAR FLOOD EVENT) OR ACTIVE FAULT LINES (POST-HOLOCENE) IN THE PROJECT AREA.
10. THE RIPARIAN CORRIDOR ALONG THOMAS CREEK IS APPROXIMATELY 40-FT. WIDE. NO WETLAND DELINEATION HAS BEEN PERFORMED FOR THIS SITE.
11. SLOPES GREATER THAN 15% AND 30% ARE SHOWN ON THE SITE PLAN. SEE THE LEGEND FOR COLOR CODING.
12. CRITICAL AND SENSITIVE BUFFER ZONES FOR THOMAS CREEK ARE SHOWN ON THE SITE PLAN.
13. EARTHWORK QUANTITIES:
  - a. LENGTH OF TRAIL ON FLAT (<15%) GROUND = 210-FT. LENGTH OF TRAIL ON SIDE SLOPE (>15%) = 210-FT. TOTAL LENGTH OF TRAIL = 420-FT.
  - b. MAXIMUM EXCAVATION PER LINEAL FOOT ON FLAT GROUND = 1.2 CF (0.044 CY/LF). MAXIMUM EXCAVATION PER LINEAL FOOT ON SIDE SLOPE = 4.5 CF (0.167 CY/LF).
  - c. TOTAL AMOUNT OF EXCAVATION (TRAIL AND BRIDGE) = 0.044 x 210 + 0.167 x 210 = 45 CY.
  - d. EXCAVATED MATERIAL WILL BE BROADCAST ON THE DOWNHILL SIDE OF THE TRAIL. NO MATERIAL WILL BE REMOVED FROM THE SITE.
  - e. TOTAL DISTURBED AREA (TRAIL AND BRIDGE) = 2,130 SF (0.049 AC.)
14. PROPOSED BMPs: FIBER ROLLS WILL BE PLACED AROUND THE BRIDGE ABUTMENTS AND TRAIL WITHIN 20-FT. OF CREEK BANKS TO PREVENT SEDIMENT FROM ENTERING THOMAS CREEK.
15. THERE WILL BE A MINIMUM 5-FT. GRADING SETBACK FROM THE PROPERTY BOUNDARY.
16. NO LANDSCAPING IS PROPOSED FOR THIS PROJECT. DISTURBED SLOPES OUTSIDE THE TRAIL TREAD WILL BE RESEED WITH THE SEED MIX IN TABLES ON C2.0.

ENGINEER'S NOTE: TO THE BEST OF MY KNOWLEDGE THE PROPOSED PROJECT COMPLIES WITH THE APPLICABLE PROVISIONS OF THE WASHOE COUNTY DEVELOPMENT CODE.  
CHARLES MACQUARIE, P.E. NV LICENSE NO. 7489

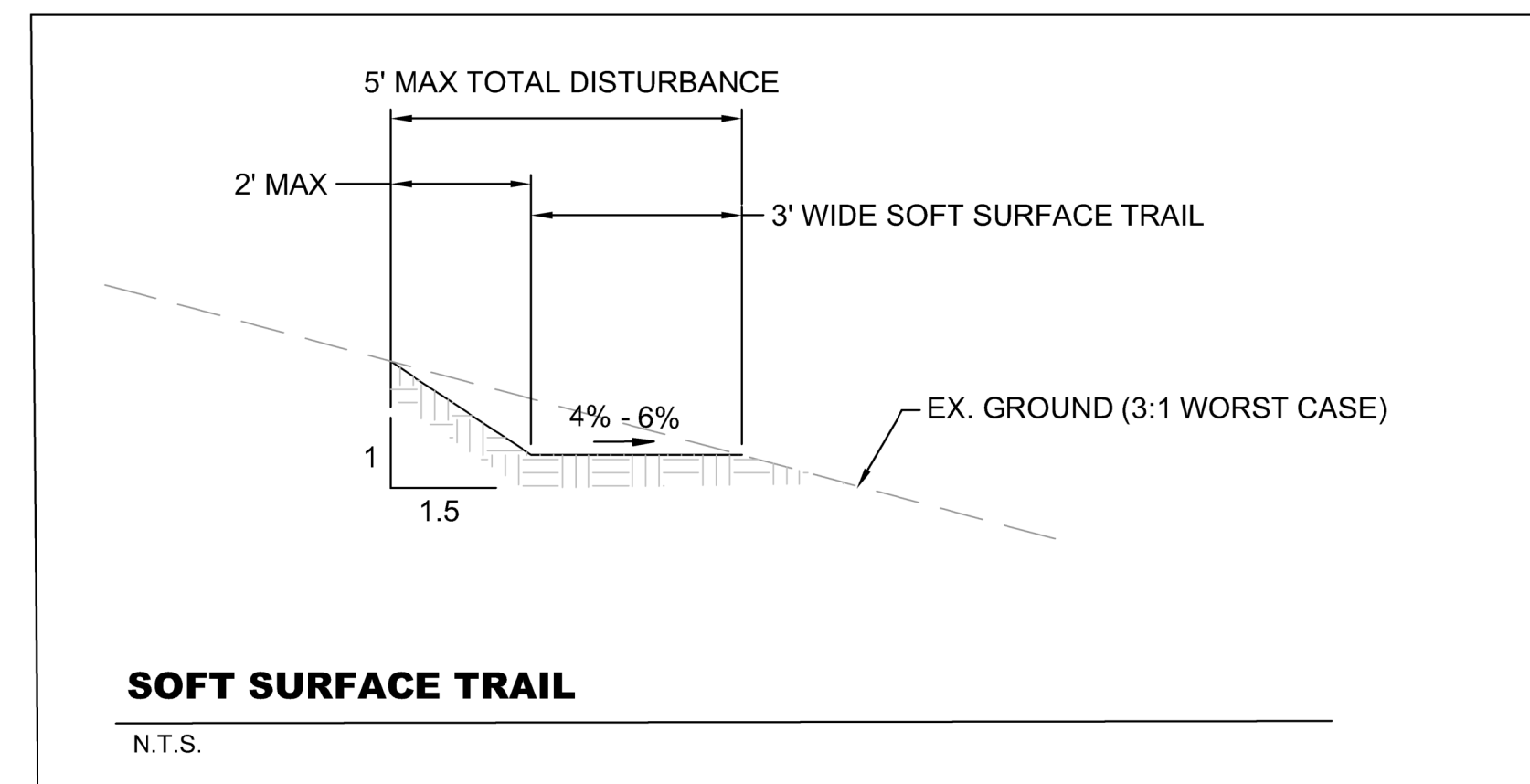

**NOTE:**

AERIAL PHOTO, TOPOGRAPHY, PROPERTY BOUNDARIES, APNs, AND FEMA FLOOD PLAIN LIMITS PROVIDED BY WASHOE COUNTY.

**LEGEND**

- SLOPES > 15%
- SLOPES > 30%



308 N. CURRY ST., STE. 200  
CARSON CITY, NV 89703  
TEL: 775.883.7077  
WWW.LUMOSINC.COM

© LUMOS & ASSOCIATES, INC. THIS DRAWING IS THE PROPERTY OF LUMOS & ASSOCIATES, INC. USE OR REPRODUCTION OF THIS DRAWING, IN WHOLE OR IN PART, WITHOUT THE WRITTEN PERMISSION OF LUMOS & ASSOCIATES, INC. IS STRICTLY PROHIBITED. THIS DRAWING IS NOT TO BE USED FOR ANY PROJECT OTHER THAN THE PROJECT FOR WHICH IT WAS PREPARED.

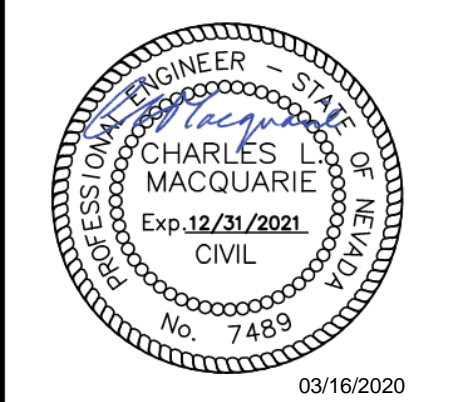

WASHOE COUNTY REGIONAL PARKS AND OPEN SPACE  
**THOMAS CREEK LOW FLOW BRIDGE**  
**EXTENDED AREA SITE PLAN**  
WASHOE COUNTY NEVADA

REV	DATE	DESCRIPTION
1	3/2/20	Sheet added to plan set



**C2.1**

DRAWN BY: BG  
DESIGNED BY: CM  
CHECKED BY: CM  
JOB NO.: 9913.000



**STRUCTURAL DRAWING ABBREVIATION LIST**

A.B.	- ANCHOR BOLT
ABT.	- ABOUT
A.F.F.	- ABOVE FINISHED FLOOR
AGGR.	- AGGREGATE
APPROX.	- APPROXIMATE
ARCH	- ARCHITECTURAL
B.B.PL	- BOTTOM OF BASE PLATE
B.C.	- BOLT CIRCLE
BLKG	- BLOCKING
BM	- BEAM
B.N.	- BOUNDARY NAILING
B.S.	- BOTH SIDES
BOF	- BOTTOM OF FOOTING
BOT. (OR BTM.)	- BOTTOM
BTWN	- BETWEEN
BW	- BOTH WAYS
C-C	- CENTER TO CENTER
C.I.P.	- CAST-IN-PLACE
CJ	- CONTROL JOINT
C.L. (OR $\emptyset$ )	- CENTERLINE
CLR	- CLEAR
CMU	- CONCRETE MASONRY UNIT
CONC.	- CONCRETE
CONT.	- CONTINUOUS
DBA	- DEFORMED BAR ANCHOR
DIA. (OR $\emptyset$ )	- DIAMETER
DO (OR 'do')	- REPEAT INDICATED STRUCT. MEMBER
DWG.	- DRAWING
DWL	- DOWEL
EA.	- EACH
E.F.	- EACH FACE
EL. (OR ELEV.)	- ELEVATION
EMBED.	- EMBEDMENT
E.N.	- EDGE NAILING
EQ	- EQUAL
E.W.	- EACH WAY
(E)	- EXISTING
FD	- FLOOR DRAIN
F.F.	- FAR FACE
F.F.L.	- FINISHED FLOOR
F.N.	- FIELD NAILING
F.O.	- FACE OF
F.S.	- FAR SIDE
FTG	- FOOTING
GA	- GAGE
GALV.	- GALVANIZED
HDR	- HEADER
H.P.	- HIGH POINT
HSA	- HEADED STUD ANCHOR
H.S.B.	- HIGH STRENGTH BOLT
I.D.	- INSIDE DIAMETER
INV. (OR I.E.)	- INVERT (INVERT ELEVATION)
I.F.	- INSIDE FACE
K	- KIP
L.P.	- LOW POINT
L.L.V.	- LONG LEG VERTICAL
MAX	- MAXIMUM
MB	- MACHINE BOLT
MECH.	- MECHANICAL
MIN.	- MINIMUM
(N)	- NEW
N.F.	- NEAR FACE
N.I.C.	- NOT IN CONTRACT
N.S.	- NEAR SIDE
N.T.S.	- NOT TO SCALE
O.F.	- OUTSIDE FACE
O.C.	- ON CENTER
OPP.	- OPPOSITE
PL. (OR $\emptyset$ )	- PLATE
P.T.	- PRESSURE TREATED
RD	- ROOF DRAIN
REINF	- REINFORCING
REQS	- REQUIREMENTS
SAD	- SEE ARCHITECTURAL DRAWINGS
S.A.P.	- SHOP ASSEMBLED PIECE
SCJ	- SLAB CONTROL JOINT
SIM	- SIMILAR
SQ.	- SQUARE
STD	- STANDARD
STRUCT.	- STRUCTURAL
SW	- SHEAR WALL
SYM.	- SYMMETRICAL
T & B	- TOP AND BOTTOM PIECE
TJ	- TIED JOINT
T.O.C.	- TOP OF CONCRETE
T.O.L.	- TOP OF LEDGER
T.O.M.	- TOP OF MASONRY
T.O.S.	- TOP OF STEEL
T.O.W.	- TOP OF WALL
TC	- TOP OF CURB
TS	- TOP OF SLAB
TRANS.	- TRANSVERSE
TYP.	- TYPICAL
U.N.O.	- UNLESS NOTED OTHERWISE
VERT.	- VERTICAL
W.P.	- WORK POINT
WI	- WITH
W/O	- WITHOUT
WS	- WATERSTOP
WWF	- WELDED WIRE FABRIC
#	- SIZE OF DEFORMED REINFORCING BAR
@	- CENTER TO CENTER SPACING

**SYMBOLS**

VIEW IN SECTION	
MATERIAL	NEW
CONCRETE	
STRUCTURAL STEEL	
BRICK OR BLOCK	
GROUT	
PLYWOOD SHEATHING	
WOOD STRUCTURAL	
GRAVEL BASE/MATERIAL	
SOIL	
STRUCTURAL FILL	
RIP-RAP	
EPOXY ANCHOR	
EXPANSION ANCHOR	
VIEW IN PLAN	
WOOD GRAIN FINISH	
TREAD PLATE	
GRATING	

**BUILDING MATERIALS LEGEND**

NOT TO SCALE  
NOTE: EXISTING MATERIALS WILL BE SHOWN SCREENED.

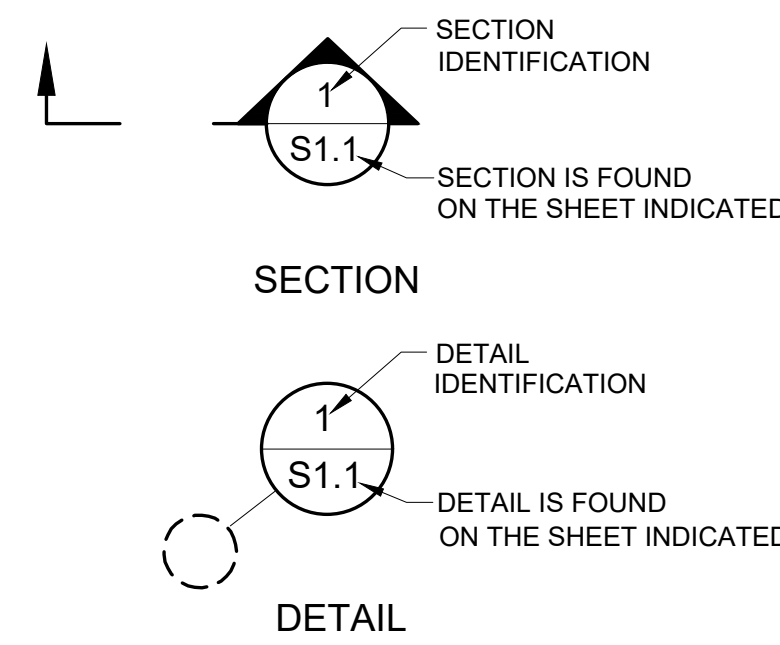

**DRAWING CROSS-REFERENCE**

NOT TO SCALE

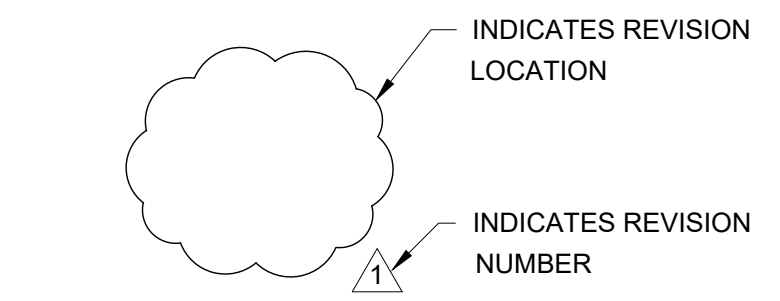

**REVISION NOTATIONS**

NOT TO SCALE

**GENERAL STRUCTURAL NOTES**

- 1. BASIS OF DESIGN**  
A. CODE: INTERNATIONAL BUILDING CODE, 2018 EDITION  
AASHTO GUIDE FOR PEDESTRIAN BRIDGES
- B. LIVE LOADS:**
- BRIDGE DECK 90 PSF
- C. SNOW LOADS:**
- GROUND SNOW LOAD,  $P_g$  30 PSF
- D. WIND LOADS - MWFRS:**
- BASIC WIND DESIGN SPEED,  $V$  120 MPH
  - ALLOWABLE STRESS DESIGN SPEED,  $V_{asd}$  93 PSF
  - RISK CATEGORY II
  - EXPOSURE C
- E. SEISMIC:**
- RISK CATEGORY II
  - MAPPED SPECTRAL RESPONSE ACCELERATION,  $S_s$  2.019
  - MAPPED SPECTRAL RESPONSE ACCELERATION,  $S_1$  0.715
  - SITE CLASS D-Default
  - DESIGN SPECTRAL RESPONSE ACCELERATION,  $S_{DS}$  1.615
  - SEISMIC DESIGN CATEGORY D
- F. STREAM PRESSURES:**
- $V_{avg} = 6.7$  FPS
  - $K = 1.4$  (PIERS SUBJECT TO DRIFT BUILD-UP)
  - $P_{avg} = 68$  PSF
- G. SOIL CRITERIA:**
- FOUNDATION DESIGN IS IN ACCORDANCE WITH IBC TABLE 1806.2 - PRESUMPTIVE LOAD-BEARING VALUES, FOR CLASS 4 MATERIALS: SAND, SILTY SAND, CLAYEY SAND, SILTY GRAVEL AND CLAYEY GRAVEL (SW, SP, SM, SC, GM AND GC).
  - DESIGN OF FOUNDATIONS AND WALLS IS BASED ON THE FOLLOWING CRITERIA:
    - ALLOWABLE BEARING PRESSURE (DL + LL) 2000 PSF
    - ALLOWABLE BEARING PRESSURE (DL + LL + LATERAL) 2667 PSF
    - LATERAL BEARING PRESSURE (BELOW NATURAL GRADE) 150 PSF/FT
    - COEFFICIENT OF FRICTION FOR SLIDING 0.25
  - VERIFICATION OF THE PRESUMPTIVE SOIL CLASSIFICATION CRITERIA IS THE RESPONSIBILITY OF THE GENERAL CONTRACTOR.
- 2. GENERAL**
- A. ALL CONSTRUCTION SHALL BE IN ACCORDANCE WITH THESE SPECIFICATIONS, THE REFERENCED CODES AND THE REQUIREMENTS OF WASHOE COUNTY.
- B. THE GENERAL CONTRACTOR SHALL REFER TO DRAWINGS AND/OR SPECIFICATIONS BY OTHERS FOR ALL ADDITIONAL INFORMATION PERTINENT TO THE CONSTRUCTION OF THE PROJECT. IT IS THE CONTRACTOR'S RESPONSIBILITY TO THOROUGHLY REVIEW THESE DOCUMENTS PRIOR TO CONSTRUCTION.
- C. WHERE DISCREPANCIES OCCUR BETWEEN PLANS, DETAILS, AND GENERAL STRUCTURAL NOTES, NOTIFY THE ENGINEER IMMEDIATELY FOR RESOLUTION.
- D. SHOULD CLARIFICATIONS REGARDING THE INTENT OF THE DESIGN BE REQUIRED, THE CONTRACTOR SHALL SUBMIT REQUESTS FOR INFORMATION (RFIS) TO THE ENGINEER. RFIS SHALL INCLUDE A DETAILED WRITTEN STATEMENT THAT INDICATES THE SPECIFIC DRAWINGS OR SPECIFICATIONS IN NEED OF CLARIFICATION AND THE NATURE OF THE CLARIFICATION REQUIRED. THE ENGINEER SHALL RESPOND IN WRITING AND ISSUE CLARIFICATIONS AS NECESSARY. RESPONSES TO RFIS ARE NOT TO BE CONSIDERED AS APPROVED CHANGE ORDERS.
- E. THE CONTRACT DOCUMENTS REPRESENT THE FINISHED STRUCTURE. THE GENERAL CONTRACTOR IS RESPONSIBLE FOR THE MEANS, METHODS, TECHNIQUES, PROCEDURES, AND SEQUENCE OF CONSTRUCTION. IT IS THE GENERAL CONTRACTOR'S SOLE RESPONSIBILITY TO PROVIDE ALL MEASURES REQUIRED TO PROTECT THE STRUCTURE, WORKMEN, AND OTHER PERSONS DURING CONSTRUCTION AND TO PROVIDE ADEQUATE SHORING AND BRACING TO MAINTAIN THE INTEGRITY OF ALL ELEMENTS OF THE STRUCTURE AND EACH AFFECTED SYSTEM DURING CONSTRUCTION. DESIGN OF SHORING, BRACING, SCAFFOLDING, ETC. WHICH ARE REQUIRED TO FACILITATE THE MEANS AND METHODS OF CONSTRUCTION SHALL BE THE SOLE RESPONSIBILITY OF THE GENERAL CONTRACTOR.
- F. THE DRAWINGS SHALL NOT BE SCALED. THE GENERAL CONTRACTOR ASSUMES ALL RESPONSIBILITY FOR USING SCALED DIMENSIONS WHICH HAVE NOT BEEN VERIFIED.
- G. CHANGES OR DEVIATIONS FROM THE STRUCTURAL DRAWINGS ARE NOT ALLOWED WITHOUT WRITTEN AUTHORIZATION FROM THE ENGINEER.
- 3. ALTERNATIVES (SUBSTITUTIONS)**
- A. THE ENGINEER WILL CONSIDER ALTERNATIVES FOR STRUCTURAL MATERIALS AND PROCEDURES AS SPECIFIED IN THE CONTRACT DOCUMENTS PROVIDED THE ALTERNATIVE DOES NOT CAUSE AN INCREASE IN COST OR DELAY THE PROJECT IN ANY MANNER. IT IS THE RESPONSIBILITY OF THE GENERAL CONTRACTOR TO DEMONSTRATE THAT ALL ALTERNATIVES ARE EQUIVALENT IN STRENGTH, PERFORMANCE, AND DURABILITY TO THE MATERIALS OR PROCEDURES SPECIFIED IN THE CONTRACT DOCUMENTS. STRUCTURAL CALCULATIONS AS PREPARED BY OTHERS SHALL BE SUBMITTED AS REQUIRED BY THE ENGINEER.
- B. THE ENGINEER'S WRITTEN APPROVAL IS REQUIRED PRIOR TO USING ANY ALTERNATIVE. CONSIDERATION OF ANY ALTERNATIVE SUBMITTAL SHALL NOT IMPLY ADVANCE ACCEPTANCE BY THE ENGINEER.
- C. THE ENGINEER WILL REQUIRE SUFFICIENT TIME TO ADEQUATELY EVALUATE ANY PROPOSED ALTERNATIVE. THE CONTRACTOR SHALL SUBMIT AN ALTERNATIVE SUBMITTAL SUFFICIENTLY IN ADVANCE TO AVOID DELAY TO THE WORK. THE ENGINEER RESERVES THE RIGHT TO REJECT ANY ALTERNATIVE. SUCH REJECTION SHALL NOT BE GROUNDS FOR DELAYS IN WORK OR AN INCREASE IN THE CONTRACT AMOUNT.
- D. ALTERNATIVE SUBMITTALS SHALL BE SUBMITTED TO THE ENGINEER AS STAND-ALONE DOCUMENTS INDEPENDENT OF SHOP DRAWINGS, MATERIAL CERTIFICATIONS, AND OTHER SUBMITTAL REQUIREMENTS. AS A MINIMUM, EACH ALTERNATIVE SUBMITTAL SHALL CONFORM TO, BUT NOT BE LIMITED TO, THE FOLLOWING REQUIREMENTS:
- ALTERNATIVE SUBMITTALS SHALL BE EQUIVALENT IN ALL RESPECTS TO THE SPECIFIED ITEM AND SHALL COMPLY WITH ALL APPLICABLE CODES AND REGULATIONS.
  - ALTERNATIVE SUBMITTALS SHALL NOT ALTER OR MODIFY THE DESIGN INTENT, FUNCTION, PERFORMANCE, APPEARANCE, OR PROPORTIONS OF THE SPECIFIED ITEM.
  - ALTERNATIVE SUBMITTALS SHALL INCLUDE LEGIBLE, COMPLETE, AND PROPERLY COORDINATED TECHNICAL DATA, SUCH AS ICC EVALUATION REPORTS, AS WELL AS OTHER RELEVANT INFORMATION REQUIRED BY THE ENGINEER TO ADEQUATELY EVALUATE THE ALTERNATIVE. THE CONTRACTOR SHALL PROMPTLY SUBMIT ADDITIONAL DATA AS DIRECTED BY THE ENGINEER, AT NO ADDITIONAL COST TO THE OWNER.
- E. THE ENGINEER'S ACCEPTANCE OF AN ALTERNATIVE SHALL NOT RELIEVE THE CONTRACTOR FROM RESPONSIBILITY FOR COMPLIANCE WITH ALL REQUIREMENTS OF THE CONTRACT DOCUMENTS. THE CONTRACTOR, AT HIS OWN EXPENSE, SHALL COORDINATE AND OTHERWISE BE RESPONSIBLE FOR ANY CHANGES IN THE WORK OF SUB-CONTRACTORS AND ALL OTHER AFFECTED PARTIES, WHICH MAY BE CAUSED BY THE ACCEPTANCE OF AN ALTERNATIVE.

**4. FOUNDATIONS**

- A. THE SUBGRADE BELOW FOOTINGS SHALL BE EVALUATED BY A GEOTECHNICAL ENGINEER TO VERIFY THAT IT IS IN CONFORMANCE WITH THE PRESUMPTIVE DESIGN CRITERIA NOTED IN THE BASIS OF DESIGN. IN THE EVENT THAT THE SUBGRADE DOES NOT MEET THE CRITERIA NOTED, THE ENGINEER SHALL BE IMMEDIATELY NOTIFIED TO REVIEW THE FOUNDATION DESIGN. VERIFICATION SHALL INCLUDE SAMPLING AND TESTING AS REQUIRED.
- B. SUBGRADE SOILS THAT WILL NOT PROVIDE THE MINIMUM BEARING CAPACITY OR THAT ARE FINE-GRAINED, LOOSE, WET, ORGANIC OR SOILS OTHERWISE JUDGED UNSUITABLE BY THE GEOTECHNICAL ENGINEER SHALL BE REMOVED AND REPLACED WITH STRUCTURAL FILL IN ACCORDANCE WITH THE GEOTECHNICAL ENGINEERS RECOMMENDATIONS.

**5. BOLTS**

- A. BOLTS IN WOOD SHALL CONFORM TO ASTM A307 AND SHALL BE HOT DIP GALVANIZED. BOLTS SHALL BE INSTALLED IN HOLES BORED WITH A BIT 1/16" LARGER THAN THE DIAMETER OF THE BOLT. BOLTS SHALL PROJECT FROM ADJACENT SURFACES TO ALLOW THE INSTALLATION OF A FULLY ENGAGED NUT AND WASHER.
- B. NUTS SHALL BE HEAVY HEX NUTS AND SHALL CONFORM TO ASTM A563. WASHERS USED FOR BOLTS SHALL BE HEAVY PLATE WASHERS CONFORMING TO ASTM A36. NUTS AND WASHERS EXPOSED TO WEATHER SHALL BE HOT-DIPPED GALVANIZED.

**6. WOOD**

- A. SAWN LUMBER FRAMING SHALL COMPLY WITH THE LATEST EDITION OF THE GRADING RULES OF THE WESTERN WOOD PRODUCTS ASSOCIATION (WWPA) OR THE WEST COAST LUMBER INSPECTION BUREAU (WCLIB). ALL LUMBER SHALL BE STAMPED WITH THE GRADE MARK OF THE APPROVED LUMBER GRADING AGENCY.
- B. ALL LUMBER DESIGN, MATERIALS, FABRICATION AND CONSTRUCTION SHALL CONFORM TO THE IBC 2018 EDITION AND THE NATIONAL DESIGN SPECIFICATION FOR WOOD CONSTRUCTION, 2018 EDITION, ALONG WITH ITS SUPPLEMENT OF WOOD DESIGN VALUES.
- C. UNLESS NOTED OTHERWISE, SAWN LUMBER FRAMING SHALL HAVE THE MINIMUM GRADE AS FOLLOWS:
- 2x6 FLAT DECKING DOUGLAS FIR NO. 2 OR BETTER
  - 2x4 JOISTS DOUGLAS FIR NO. 2 OR BETTER
  - BEAMS (5" AND LARGER) DOUGLAS FIR NO. 2 OR BETTER
- NOTE:** FRAMING MATERIALS MAY NOT BE CHANGED WITHOUT THE WRITTEN APPROVAL OF THE ENGINEER.
- D. ALL SAWN LUMBER FRAMING MATERIALS WITH A GRADE OF NO. 2 OR BETTER SHALL HAVE MOISTURE CONTENT AT THE TIME OF PLACEMENT OF 19% OR LESS.
- E. EXPOSED LUMBER SHALL BE INSTALLED IN A FINISH-LIKE MANNER.
- F. MATERIAL FOR SILL PLATES SHALL BE AS FOLLOWS:
- PRESERVATIVE TREATED WOOD USING CORROSION RESISTANT CONNECTORS AND FASTENERS.
    - PRESERVATIVE SHALL BE AN ALKALINE COPPER QUATERNARY (ACQ) WATERBORNE PRESERVATIVE PER IBC SECTION 2304.11.2.
    - FASTENERS SHALL BE AS SPECIFIED IN SECTIONS 7.C AND 8.B BELOW.
    - CONNECTORS SHALL BE AS SPECIFIED IN PARAGRAPH G. BELOW.
  - SIMPSON CONNECTORS IN CONTACT WITH ACQ PRESERVATIVE TREATED WOOD SHALL BE SIMPSON ZMAX (OR EQUAL) OR HOT DIP GALVANIZED PER ASTM A153.
  - FOR CONNECTORS NOT IN CONTACT WITH PRESERVATIVE TREATED WOOD, THE MINIMUM PROTECTION SHALL BE THE MANUFACTURER'S STANDARD GALVANIZED SYSTEM.

**7. NAILS**

- A. USE COMMON WIRE NAILS UNLESS OTHERWISE NOTED. ALTERNATIVE NAIL TYPES OF EQUIVALENT SIZE AND STRENGTH MAY BE USED SUBJECT TO MEETING THE REQUIREMENTS OF THE IBC AND SUBJECT TO PRE-APPROVAL BY THE ENGINEER. IT IS THE CONTRACTOR'S RESPONSIBILITY TO OBTAIN APPROVAL PRIOR TO USING ALTERNATIVE NAILS.
- B. EDGE AND END DISTANCES IN THE DIRECTION OF STRESS SHALL NOT BE LESS THAN ONE-HALF THE REQUIRED PENETRATION AS REQUIRED BY THE INTERNATIONAL BUILDING CODE. WHERE NECESSARY TO PREVENT SPLITTING OF THE WOOD, HOLES FOR NAILS SHALL BE PRE-BORED TO A DIAMETER SMALLER THAN THAT OF THE NAIL.
- C. NAILS WHICH PENETRATE ACQ PRESERVATIVE TREATED WOOD SHALL BE STAINLESS STEEL OR HOT-DIPPED GALVANIZED TO MEET ASTM A 153 CLASS D SPECIFICATIONS.

**8. SCREWS**

- A. SCREWS SHALL BE STRONG-DRIVE SDS HEAVY-DUTY CONNECTOR SCREWS AS MANUFACTURED BY SIMPSON STRONG-TIE OR PRE-APPROVED EQUAL WITH SIZE AND SPACING AS INDICATED IN THE DRAWINGS.
- B. SCREWS IN CONTACT WITH ACQ PRESERVATIVE TREATED WOOD SHALL BE SIMPSON ZMAX (OR EQUAL) OR HOT DIP GALVANIZED PER ASTM A153.



9222 PROTOTYPE DRIVE  
RENO, NV 89521  
TEL: 775.827.6111  
WWW.LUMOSINC.COM

© LUMOS & ASSOCIATES, INC. THIS DRAWING IS THE PROPERTY OF LUMOS & ASSOCIATES, INC. USE OR REPRODUCTION OF THIS DRAWING, IN WHOLE OR IN PART, WITHOUT THE WRITTEN PERMISSION OF LUMOS & ASSOCIATES, INC. IS STRICTLY PROHIBITED. THIS DRAWING IS NOT TO BE USED FOR ANY PROJECT OTHER THAN THE PROJECT FOR WHICH IT WAS PREPARED.

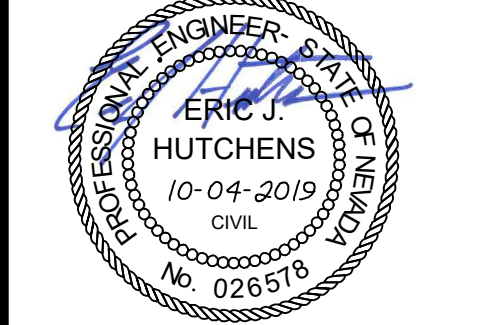

EXPIRES: JUNE 30, 2021

WASHOE COUNTY  
 THOMAS CREEK LOW FLOW BRIDGE  
 STRUCTURAL NOTES  
 WASHOE COUNTY  
 NEVADA  
 RENO

REV.	DATE	DESCRIPTION

ISSUED FOR PERMIT  
OCTOBER 4, 2019

BAR IS 1 INCH ON ORIGINAL DRAWING  
0 1

IF NOT ONE INCH ON THIS SHEET, ADJUST SCALES ACCORDINGLY

**S0.1**

DRAWN BY: B.C.E.  
DESIGNED BY: E.H.  
CHECKED BY:  
JOB NO.: 9913.000

SHEET: 1 OF 2

L:\Projects\2019\09\04\04 - Thomas Creek Low Flow Bridge\Structural\Current Drawings\ThomasCreekBridge-S1.0.dwg(S1.1, 10/04/2019 09:36 am, 0404)



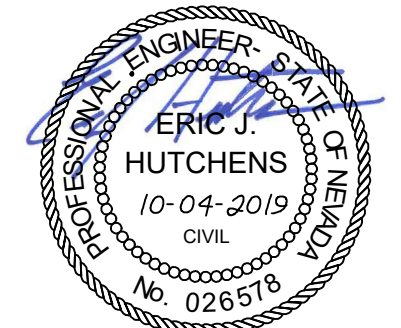

EXPIRES: JUNE 30, 2021

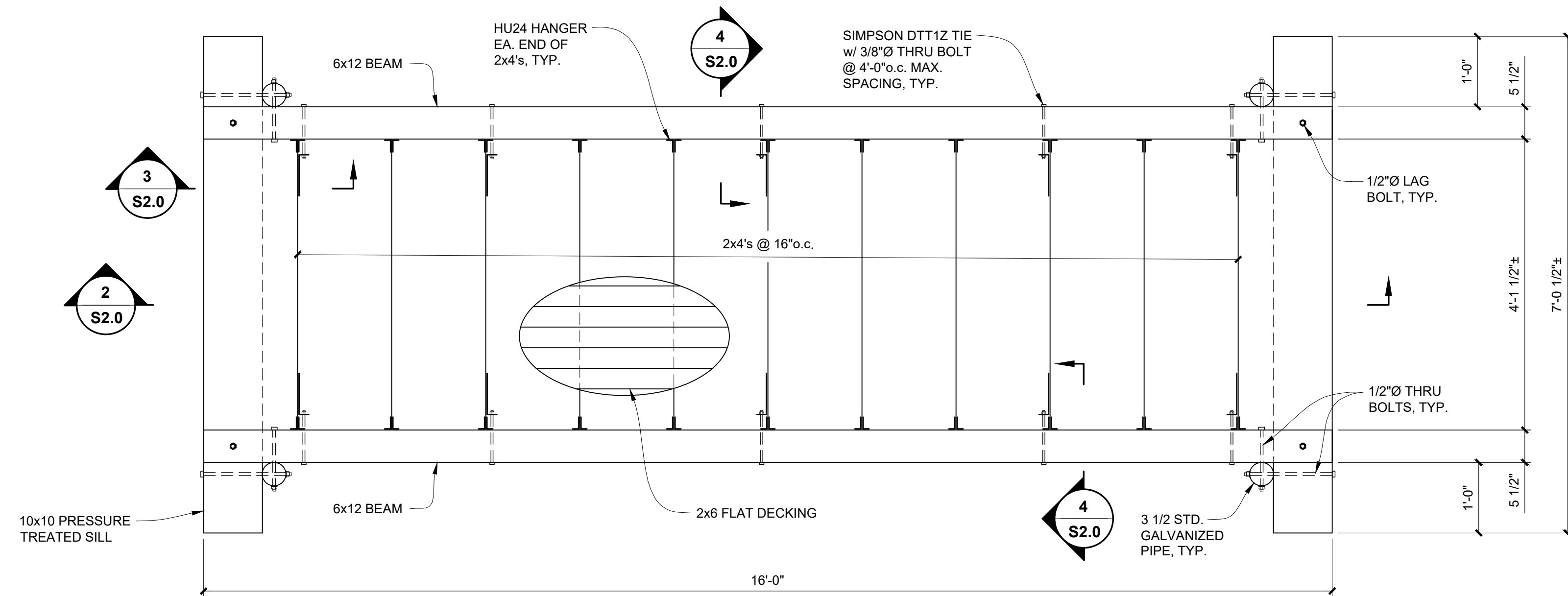

**1 BRIDGE PLAN VIEW**  
SCALE: 3/4"=1'-0"

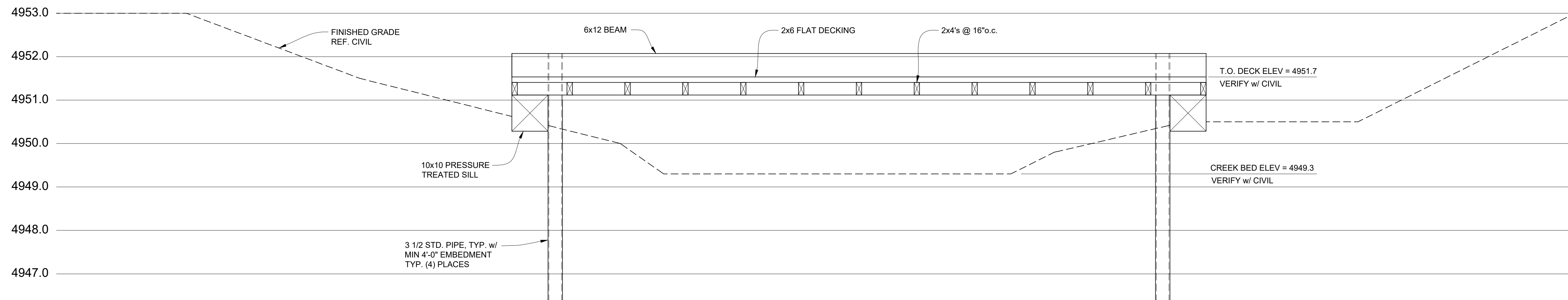

**2 BRIDGE SECTION**  
SCALE: 3/4"=1'-0"

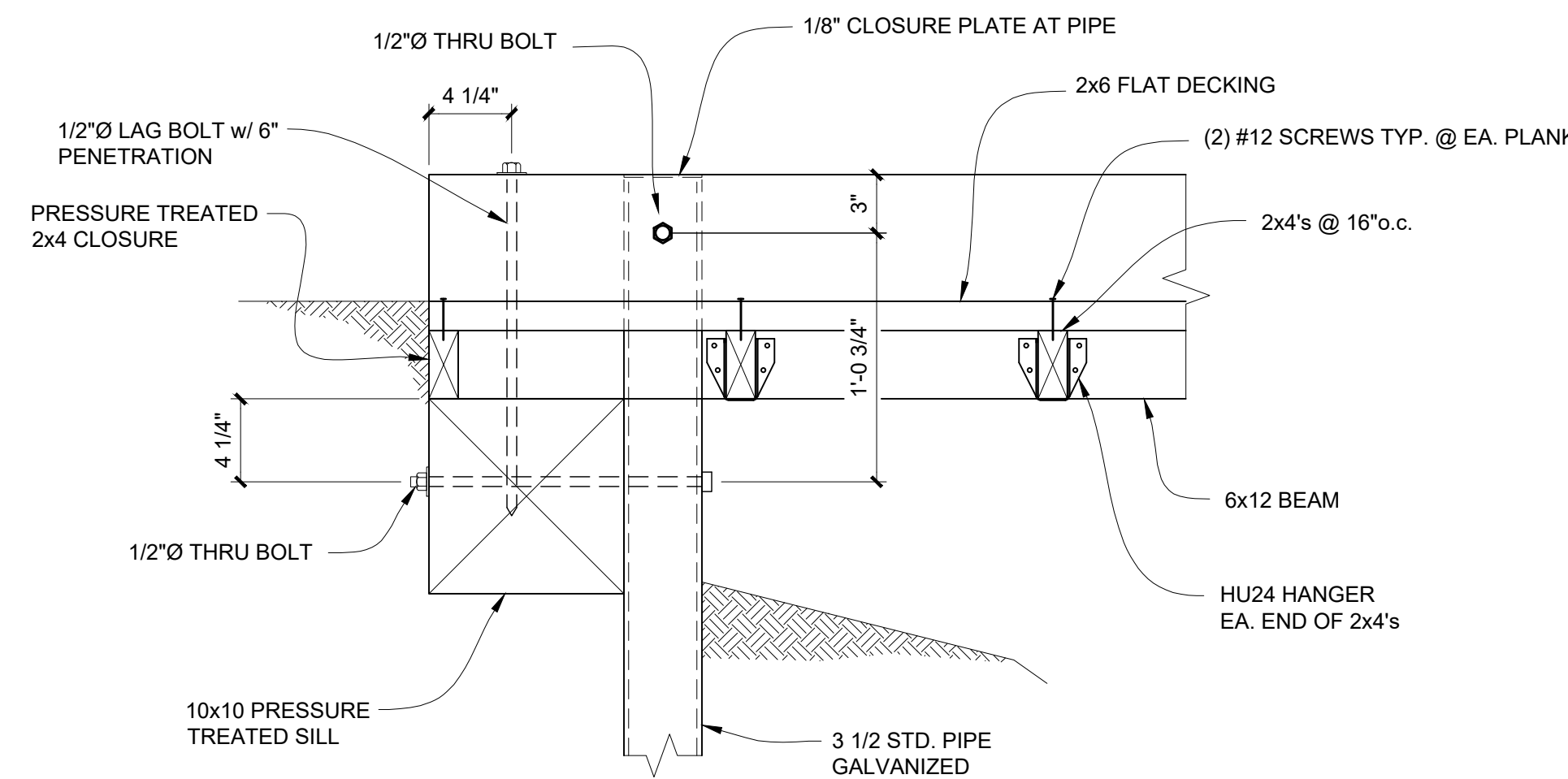

**3 CONNECTION DETAIL**  
N.T.S.

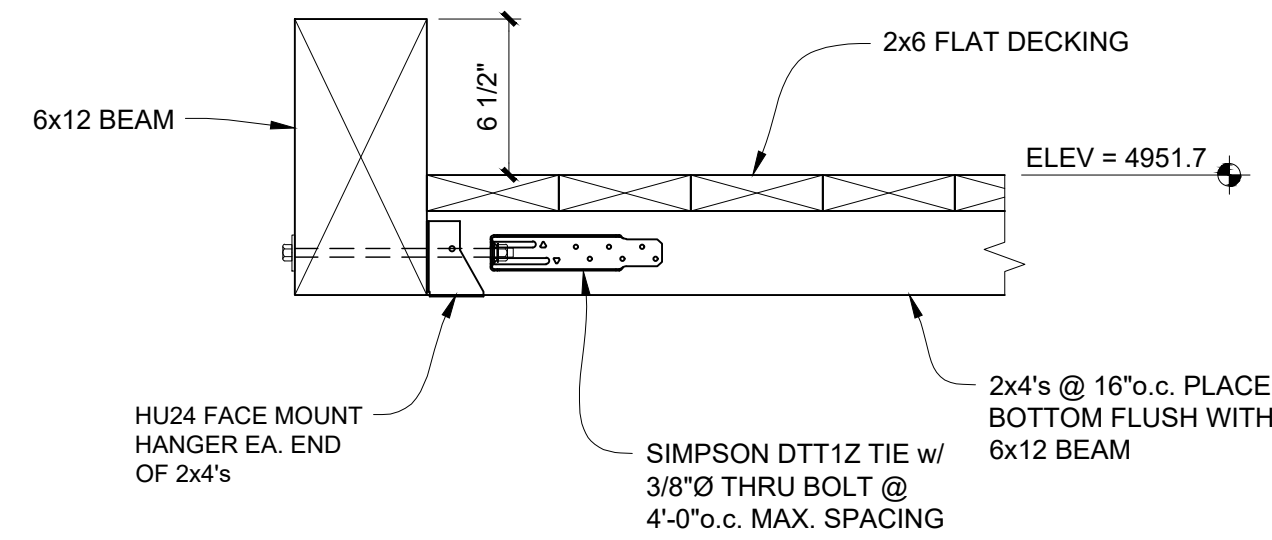

**4 CONNECTION DETAIL**  
N.T.S.

WASHOE COUNTY  
 THOMAS CREEK LOW FLOW BRIDGE  
 BRIDGE PLAN VIEW, SECTION & DETAILS  
 WASHOE COUNTY  
 NEVADA  
 RENO

REV	DATE	DESCRIPTION

ISSUED FOR PERMIT  
OCTOBER 4, 2019

BAR IS 1 INCH ON ORIGINAL DRAWING  
IF NOT ONE INCH ON THIS SHEET, ADJUST SCALES ACCORDINGLY

**S1.0**  
DRAWN BY: B.C.E.  
DESIGNED BY: E.H.  
CHECKED BY:  
JOB NO.: 9913.000

SHEET: 2 OF 2

L:\Projects\2019\10/04/2019\08:37 am\0404 Thomas Creek Low Flow Bridge\Structural\Current Drawings\ThomasCreekBridge-S1.0.dwg,S1.0, 10/04/2019 08:37 am, 0404